



MODEL FV 40.2



Undercounter High Temperature Sanitizing Dishwasher
(USA Version)

OWNER'S INSTALLATION, OPERATION AND MAINTENANCE MANUAL



Point
2

TABLE OF CONTENTS

1. INTRODUCTION	3	3.12 Priming the Detergent and Rinse Additive Lines	10
1.1 Overview of Equipment	3	3.13 Checking for Correct Chemical Concentration	10
1.2 General Safety Information	3	4. OPERATION	11
2. TRANSPORT AND SHIPPING	3	4.1 Location and Description of Controls	11
3. INSTALLATION	4	4.2 Startup	12
3.1 Overview of Installation	4	4.3 Loading	12
3.2 Requirements Before Installation	4	4.4 Operation	13
3.3 Uncrating, Positioning and Leveling	5	4.5 Between Cycles	13
3.4 Accessing the Utility Connections	5	4.6 Shutdown	13
3.5 Main Electrical Supply Connection	6	5. CLEANING	14
3.6 Dispensing System Overview	6	5.1 Daily Cleaning (or as required)	14
3.7 Installing External Chemical Pumps	7	5.2 Weekly Cleaning (or as required)	14
3.8 Connecting Chemical Containers or Dispensers	8	5.3 Exterior Cleaning (as required)	15
3.9 Fresh Water Supply Connection	9	5.4 Deliming (as required)	15
3.10 Drain Hose Positioning	9	6. TROUBLESHOOTING	16
3.11 Final Assembly	10		

AN ELECTRICAL WIRING DIAGRAM IS LOCATED INSIDE THE LOWER-FRONT COMPARTMENT OF THIS MACHINE.

THE MEIKO MODEL FV 40.2 DISHWASHER HAS BEEN DESIGNED EXCLUSIVELY FOR THE WASHING OF DISHES, GLASSWARE, CUTLERY AND KITCHEN UTENSILS IN A COMMERCIAL OR INSTITUTIONAL SETTING AND MUST NOT BE USED FOR ANY OTHER PURPOSE.

MEIKO ACCEPTS NO RESPONSIBILITY FOR DAMAGE TO THE APPLIANCE, SURROUNDING EQUIPMENT OR ENVIRONMENT THAT IS CAUSED BY INAPPROPRIATE INSTALLATION OR OPERATION, OR FROM ANY SERVICE THAT IS UNDERTAKEN BY NON-AUTHORIZED PERSONNEL, OR FROM THE USE OF ANY PARTS EXCEPT THOSE THAT ARE APPROVED BY THE MANUFACTURER. ANY SUCH INSTALLATION, USE OR SERVICE WILL IMMEDIATELY VOID THE MANUFACTURER'S WARRANTY.

ANY MODIFICATIONS TO THE APPLIANCE THAT ARE PERFORMED WITHOUT THE WRITTEN PERMISSION OF MEIKO WILL IMMEDIATELY VOID THE MANUFACTURER'S WARRANTY.

MEIKO reserves the right to change any specifications without notice at any time.

© 2010 MEIKO USA, Inc. All rights reserved.



MEIKO • 1349 Heil Quaker Blvd. • La Vergne, TN 37086
Phone: (615) 399-6600 • (800) 55-MEIKO • Fax: (615) 399-6620
www.meiko.us

1 INTRODUCTION

1.1 Overview of Equipment

The MEIKO Model FV 40.2 is a commercial dishwasher designed for cleaning dishes, glassware, cutlery and kitchen utensils with a minimum of employee intervention or supervision.

A control keypad allows easy selection of three different dishwashing cycles to accommodate different levels of soiling. A digital display permits easy monitoring of operation.

Other features of the unit that affect operation include:

Auto Safe - An internal booster heater is regulated by the electronic control system to ensure a proper sanitizing final rinse temperature, regardless of the incoming water temperature.

Soft Start - The wash water is pumped at a reduced pressure for the first few seconds of the wash cycle. This protects the ware from being moved or damaged by a sudden burst of pressure.

Pumped Rinse - An internal rinse pump ensures that the final rinse pressure is constant.

Pumped Drain - Accommodates wall or floor drains.

Aqua Stop - The unit will automatically shut down if a water leak is detected.

For efficient and SAFE operation, be sure to follow the installation and operating instructions provided in this manual. In particular, all safety symbols and notices on the equipment and in the supplied documentation must be followed.

IMPORTANT

The Model FV 40.2 dishwasher has been designed exclusively for the washing of dishes, glassware, cutlery and kitchen utensils in a commercial or institutional setting and must not be used for any other purpose.

1.2 General Safety Information

The following symbols and headings are used throughout this manual to indicate possible hazards to persons or to the equipment. The symbols and headings are shown in order of importance. The descriptive text following these headings is *italicized* for easy recognition.



WARNING! *Possible hazard to persons, such as from electrical shock, crushing, or hot surfaces.*

CAUTION

Possible hazard to the dishwasher or to other equipment.

IMPORTANT

Vital information or tips for the installer or operator.

NOTE

Information or tips for the installer or operator.

2 TRANSPORT AND SHIPPING

CAUTION

During shipping and installation, the dishwasher may ONLY be positioned upright or on its left side. Some water may remain in the lines after pre-shipping testing. If the unit is positioned in any manner EXCEPT upright or on its left side, this water can affect the operation of the water level sensor.

IMPORTANT

- *Observe any notices on the crating material that pertain to shipping.*
- *Use care when transporting the equipment.*
- *As you unpack the equipment, check that all components shown on the shipping invoice are present and intact. Be sure to check for shipping damage. If shipping damage is present, call MEIKO Customer Service at 1-800-868-3840, providing full details on the customer, serial number and extent of damage present. MEIKO will file a freight claim based on this information.*



WARNING! *In NO EVENT should a damaged appliance be installed or operated!*

3 INSTALLATION

3.1 Overview of Installation

The owner should contract with qualified personnel to move the appliance to the installation location, unpack it, and prepare it for final utility connections. In most cases, local codes prevent the final utility connections from being made by any party other than a licensed electrician and/or plumber.

IMPORTANT

It is the responsibility of the owner to ensure that all aspects of the installation comply with all applicable local and national codes.

IMPORTANT

The appliance's warranty is not valid until a MEIKO Authorized Service Agent performs a Startup and Demonstration on the appliance. This Demonstration should be scheduled after installation.

Installation of the dishwasher involves the following steps:

- Verifying that the utility connections are present, are appropriate for the appliance, and comply with all applicable local and national codes.
- Unwrapping the appliance (leaving the shipping skid in place for easier movement) and checking for shipping damage.
- Moving the appliance to the installation location, removing the skid, and leveling the feet.
- Connecting the electrical supply.
- Installing the chemical dispensing system.
For units equipped with the optional dispensing system, this involves connecting the warewasher's detergent and rinse additive tubes to appropriate dispensers.
For units without the optional system, the dispensing system installer should follow the manufacturer's instructions AND the instructions in Section 3 of this Manual.
- Connecting the fresh water supply.
- Positioning the drain hose.

- Contacting your MEIKO Authorized Service Agent to perform a Startup and Demonstration on the appliance. This step also validates the appliance's warranty.

3.2 Requirements Before Installation

Before the installer can uncrate and move the appliance to the installation location, the following conditions MUST be met:

- **INSTALLATION AREA REQUIREMENTS**
 - The area MUST be frost-free. Freezing temperatures (32°F/0°C or lower) inhibit proper operation and can damage internal components.
 - The area MUST have a firm floor surface. It is possible to compensate for uneven flooring by adjusting the feet.
 - The area should be away from appliances, furniture or surfaces that can be damaged by steam. If this is not possible, these items should be protected from the small quantities of steam that are released during normal operation of the dishwasher.
- **UTILITY CONNECTION REQUIREMENTS**
 - Connections must be present and ready for hookup to the appliance. All utility supplies must comply with the electrical information labels, with the information on the data plate, and with all applicable local and national codes.
 - Electrical leads and the water supply hose (supplied by the customer) must be present.
 - For units without the optional dispensing system, external detergent and rinse additive pumps (if used) should be installed according to the manufacturer's instructions.
 - For units with the optional dispensing system, appropriate dispensers or containers should be installed and ready for connection to the appliance.
- **GENERAL REQUIREMENTS**
Authorized personnel should be available to perform the actual utility connections.

3.3 Uncrating, Positioning and Leveling

CAUTION

During shipping and installation, the dishwasher may **ONLY** be positioned upright or on its left side. Some water may remain in the lines after pre-shipment testing. If the unit is positioned in any manner **EXCEPT** upright or on its left side, this water can affect the operation of the water level sensor.

1. Remove all shipping and packaging material from the appliance, including supports and wrappings. Leave the shipping skid in place at this time to allow for easier movement to the installation location.
2. Check for shipping damage as described in Section 2, "Transport and Shipping." If damage is present, call MEIKO Customer Service at **1-800-868-3840**, providing full details on the customer, serial number and extent of damage present. MEIKO will file a freight claim based on this information.
3. Move the appliance to the installation area and remove the skid. Use caution to avoid damaging the appliance or any of its components.
4. Check that the plastic feet are attached to each of the four adjustable leg bolts. If necessary, attach them by pressing them firmly onto the end of the bolts.
5. Using a spirit level, check that the appliance is level in both directions (front-to-back AND side-to-side). If necessary, rotate the leg bolts to level the appliance.

CAUTION

The dishwasher **MUST** be level for proper operation.

3.4 Accessing the Utility Connections

In order to attach the utility connections, the back panel of the dishwasher must be removed. Follow the steps below.

1. Remove **AND RETAIN** the three retaining screws underneath the bottom lip of the rear panel. See Figure 3-1.
2. Carefully slide the rear panel down to free the retaining clips along the top edge. See Figure 3-2.
3. Remove the rear panel from the dishwasher.

Figure 3-1

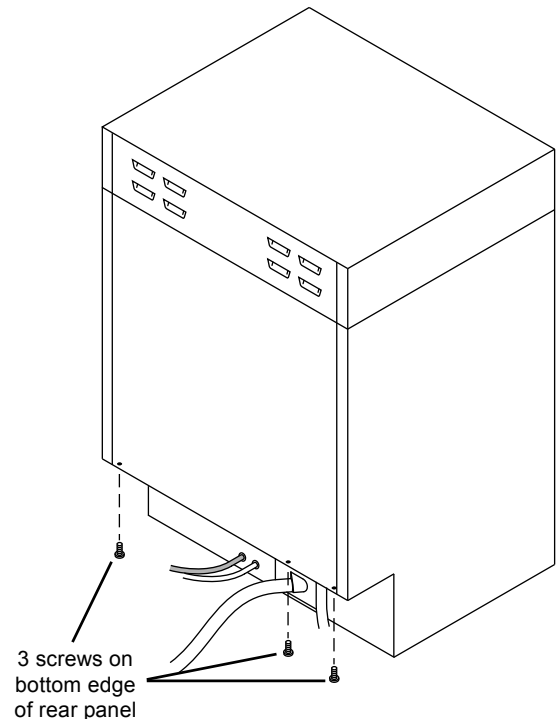
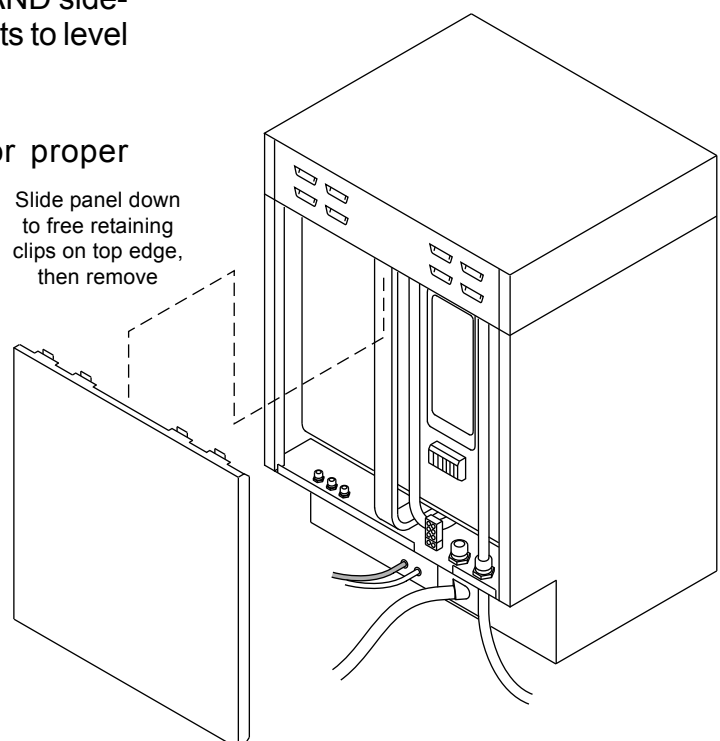

Figure 3-2



3.5 Main Electrical Supply Connection



WARNING!

Check that the circuit breaker/fused disconnect is in the OFF position and that the unit is switched off before making the electrical utility connections.

IMPORTANT

In some cases, local codes dictate that electrical supply connections be made only by a certified professional.

1. Check that the incoming power leads are of sufficient rating for the appliance's current draw. Amperage and minimum supply wire specifications are shown on the serial plate and on the electrical information label.
2. Check that the incoming power leads are long enough to permit the unit to be repositioned for servicing.
3. Locate the strain relief for the electrical supply wiring at the lower rear of the machine (Figure 3-3). Thread the incoming supply leads through the strain relief and to the main electrical supply terminal block.
4. Refer to Figure 3-4 and to the electrical wiring diagram. Connect the power supply and ground leads as indicated.
5. Adjust the strain relief to fasten the wiring in place. You should leave enough slack in the wiring to prevent stress on the terminal connections.

3.6 Dispensing system overview

The FV 40.2 is designed for use with liquid detergent and liquid rinse additive. The unit is not compatible with solid detergents and/or rinse additives.

The tubes located at the lower rear of the warewasher are pre-plumbed to supply liquid detergent (clear tube) and liquid rinse additive (blue tube). See Figure 3-3.

Some units are equipped with optional internal liquid detergent and rinse additive dispensing pumps, in which case containers can simply be attached to the supply tubes. Units without the optional internal pumps will require the

tubes to be routed to external pumps, if they are used.

CAUTION

If the unit will NOT use one or both of the chemical supply tubes, cut the unused tube(s) close to the point where it exits the machine's exterior panel and seal it using the supplied plug and wire clamp. See Figure 3-5.

For units equipped with the optional internal chemical dispensing system, skip ahead to Section 3.8, "Connecting Chemical Containers or Dispensers."

Figure 3-3: Utility connections

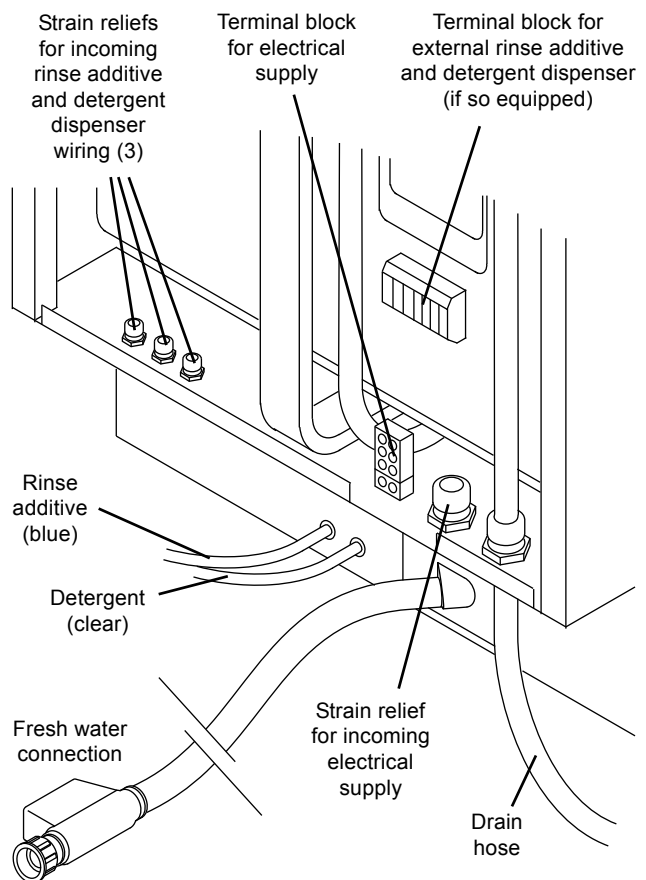

Figure 3-4: Main electrical supply

- 208-230V/1 Phase:
L1 and L2 = "hot" (line)
yel/grn = ground
- 208-230V/3 Phase
L1, L2, L3 = "hot" (line)
yel/grn = ground

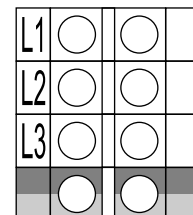
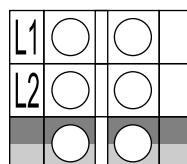
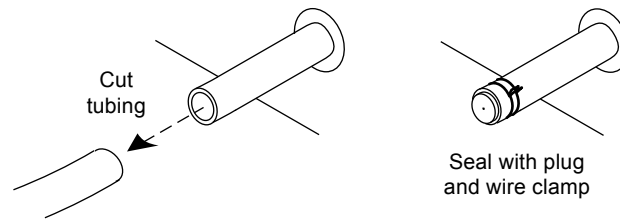

Figure 3-5: Sealing unused chemical tubes (if not using a liquid detergent or rinse additive)



3.7 Installing External Chemical Pumps (if so equipped)

IMPORTANT

Some local codes dictate that electrical connections be made only by a certified professional.

The machine's dispensing terminal block includes relays that close during specific times in the cycle. The closed relays complete a circuit, creating a "window" that allows activation of external chemical dispensers.

- The rinse additive relay is closed for 16.5 seconds when the booster tank begins its fill cycle. A timer in the external system should be used to regulate the amount of rinse additive injected per cycle.
- The detergent relay is closed whenever the wash pump is in operation.

IMPORTANT

It is **HIGHLY RECOMMENDED** to use a timer system to control detergent injection, **NOT** a detergent concentration probe.

Two pre-plumbed 1/4" ID tubes serve as the connection points for the chemical supplies. The CLEAR tube supplies detergent, and the BLUE tube supplies rinse additive.

To install external chemical dispensers:

1. Check that the pump(s) are correctly installed according to the manufacturer's instructions.
2. Locate the chemical dispenser terminal block. See Figure 3-3.
3. Thread the incoming leads from the chemical pumps through the strain reliefs (at the lower rear of the machine) and to the chemical dispenser terminal block.

4. Connect the wires as shown in Figure 3-6. Note that the terminal block supplies **LINE VOLTAGE SIGNALS**. An additional transformer may be required depending on the supply requirements of the external pumps.
5. Adjust the strain reliefs to fasten the wiring in place. Leave enough slack in the wiring to prevent stress on the terminal connections. Bundle the wires together using wire ties to prevent them from tangling when repositioning the appliance.

Figure 3-6: External chemical pump connections

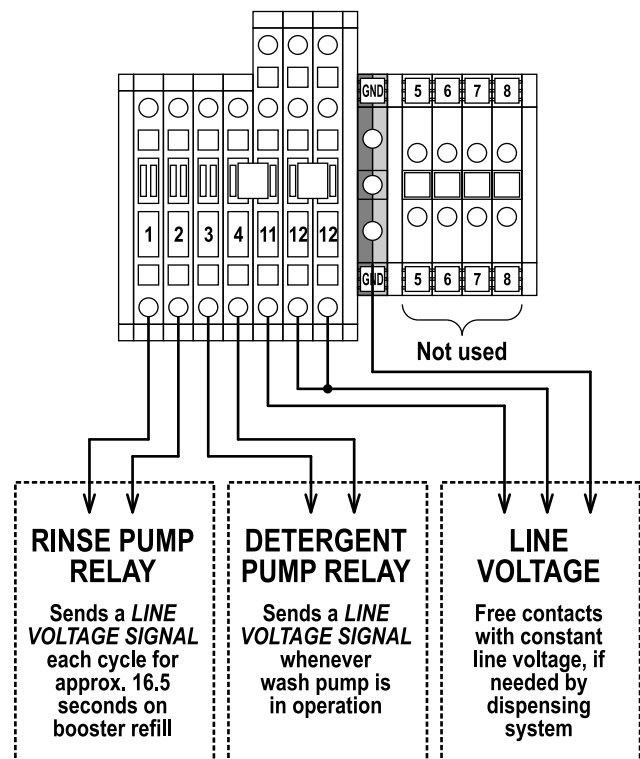

3.8 Connecting Chemical Containers or Dispensers (if so equipped)

This section applies to units with either internal or external chemical dispensing pumps.

1. Check that the rinse additive and detergent are compatible with the unit. In particular, a commercial (not a domestic) LIQUID detergent **MUST** be used. The Model FV40.2 is not compatible with solid detergents and/or rinse additives.
2. Check that the containers/dispensers are correctly installed according to the manufacturer's instructions.
3. If the dishwasher is equipped with factory internal chemical dispensing pumps, two strainer assemblies for the chemical containers are also included. See Figure 3-7. These strainers should be assembled onto the lids for the detergent and rinse additive containers.
4. Locate the CLEAR liquid detergent supply tube at the lower rear of the unit. Connect the tubing to the detergent container.
5. Locate the BLUE liquid rinse additive supply tube at the lower rear of the unit. Connect the tubing to the rinse additive container.
6. If using the strainers shown in Figure 3-7, be sure to use the supplied wire clamps to fasten the chemical supply tubes securely. **MEIKO STRONGLY RECOMMENDS** the use of a sealing compound on these connections to prevent leakage.

Figure 3-7: Strainer assembly

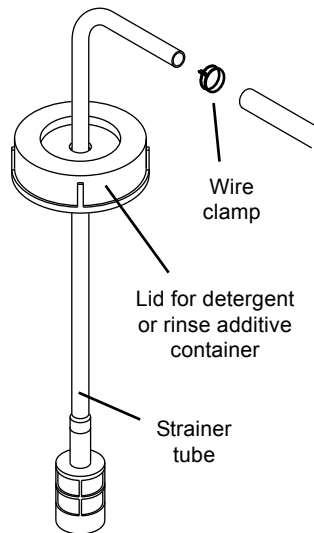

3.9 Fresh Water Supply Connection

CAUTION

Before connecting the water supply hose, the line **MUST** be flushed clean of all debris, including (but not limited to) pipe sealant, metal particles, solder, etc. This debris can damage the appliance.

IMPORTANT

In some cases, local codes dictate that water supply connections be made only by a certified professional.

1. Check that iron or other metal particles cannot contaminate the fresh water supplied to the dishwasher.
2. Check that the incoming water pressure is within the acceptable range for the appliance (8.7-72.5 psi, 0.6-5.0 bars). It may be necessary to increase the pressure (with a booster pump) or to reduce the pressure (with a reducing valve).
3. Check the incoming water temperature. MEIKO recommends a water temperature of 140°F/60°C for optimum operation, although if necessary the appliance will sanitize correctly using water at any temperature. Colder water will result in a longer preheat time (during initial startup) and may extend the cycle time to allow the final rinse water to heat to 180°F/82°C.
4. Check the incoming water hardness. MEIKO recommends a hardness of 4-6 grains per U.S. gallon.

5. Because the water inlet incorporates a stainless steel dirt trap, an additional trap is unnecessary unless required by local, national or international codes.
6. The dishwasher includes a water supply line that ends in an enclosure containing the water inlet valve and the Aqua-Stop shutoff valve (see Figure 3-8). Connect the customer-supplied water line to the fitting on the end of this enclosure. Use a sealing compound on the threads to ensure that no leaks are present in the connection.
7. Check that the water line is long enough to permit the unit to be repositioned for servicing.

3.10 Drain Hose Positioning

1. Check that the end of the drain hose will empty into a drain with a minimum diameter of 1-1/2"/38mm.
2. Check the type of drain that will be used. Because the FV 40.2 uses a pumped drain, either a floor or wall drain is acceptable.

CAUTION

No portion of a wall drain system may be higher than **24" (610m) A.F.F.** to ensure that the drain pump is operating within rated specifications. See Figure 3-9.

3. Route the drain hose to the drain. In some cases, a grease trap (supplied by others) must be fitted into the waste water line. If this trap is required for your installation, check that it is present.

Figure 3-8: Fresh water supply and drain connections

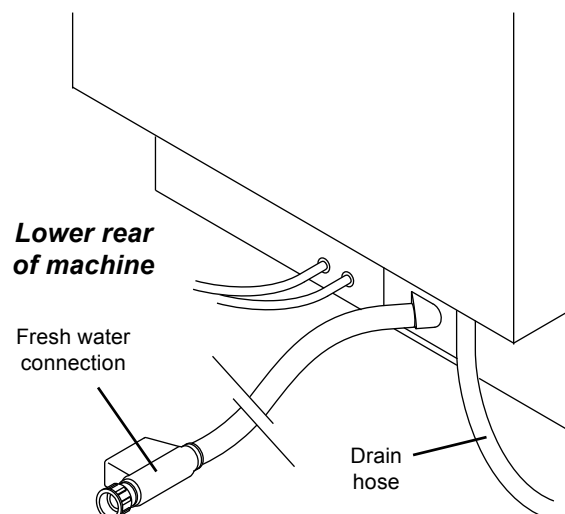
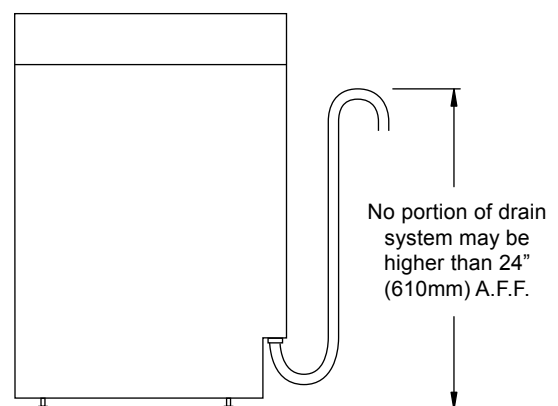

Figure 3-9: Drain line vertical rise limitations







3.11 Final Assembly

1. Check and tighten all electrical terminal screws.
2. Replace all panels onto the dishwasher.
3. Switch the circuit breaker/fused disconnect to the ON position. Be sure to prime the detergent pumps and check for correct chemical concentration before operating the unit.

3.12 Priming the Detergent and Rinse Additive Lines

For machines equipped with external chemical dispensing systems, prime the detergent and rinse additive lines according to the manufacturer's instructions.

For machines equipped with factory internal chemical dispensing systems, prime the lines as follows:

1. Press and hold the STOP/OFF (O) key until Code 1---- appears in the display (about 4-5 seconds).
2. Press the START/DRAIN () key 5 times until 1-1----- appears in the display.
3. Press the  key. 1-2----- will appear in the display.
4. Press the START/DRAIN () key to start priming the liquid rinse additive lines. A timer will count down the time remaining. By default, the system will prime for 180 seconds.
5. When the display returns to 1-2-----, press the  key so that 1-3----- appears in the display.
6. Press the START/DRAIN () key to start priming the liquid detergent lines. A timer will count down the time remaining. By default, the system will prime for 30 seconds.
7. When the display returns to 1-3-----, press the STOP/OFF (O) key to shut off the dishwasher.

3.13 Checking for Correct Chemical Concentration

Machines equipped with external chemical dispensing systems will have normal settings recommended by the manufacturer.

For machines equipped with factory internal chemical dispensing systems, the normal settings for chemical injection are:

- Detergent - 0.256 oz. per gallon of wash water (2.0 ml per liter).
- Rinse additive - 0.0256 oz. per gallon of rinse water (0.2 ml per liter).

To check if the normal settings are correct for your chemicals, *RUN THREE EMPTY LOADS* to completely cycle the water supply and obtain accurate test results. This will only take a few minutes. Then, run a sample load with soiled ware and examine the results.

- If the detergent setting is too low, the ware will not be adequately cleaned. In some cases, this can be corrected by simply selecting a longer cycle time (using the Cycle Select II, Extended or Cycle Select III, Heavy buttons), but the detergent concentration may also need to be adjusted.
- If the rinse additive setting is too low, spotting or streaking may occur on the ware.
- If too much of either chemical is added, the extra chemicals will be wasted. This is often difficult to detect except by determining how long your chemical supplies last. If the chemicals are being exhausted quickly, you may need to have the chemical concentration adjusted.

IN ALL CASES, ANY ADJUSTMENTS OF THE FACTORY CHEMICAL INJECTION SETTINGS ARE TO BE PERFORMED ONLY BY A MEIKO AUTHORIZED SERVICE AGENT. CHANGES BY UNAUTHORIZED PERSONNEL WILL VOID YOUR WARRANTY.

If you need to contact your Authorized Service Agency, please contact MEIKO Technical Support at **1-800-868-3840**.

4 OPERATION

4.1 Location and Description of Controls

The dishwasher controls are on the keypad directly above the door. See Figure 4-1.

Figure 4-1: Dishwasher controls

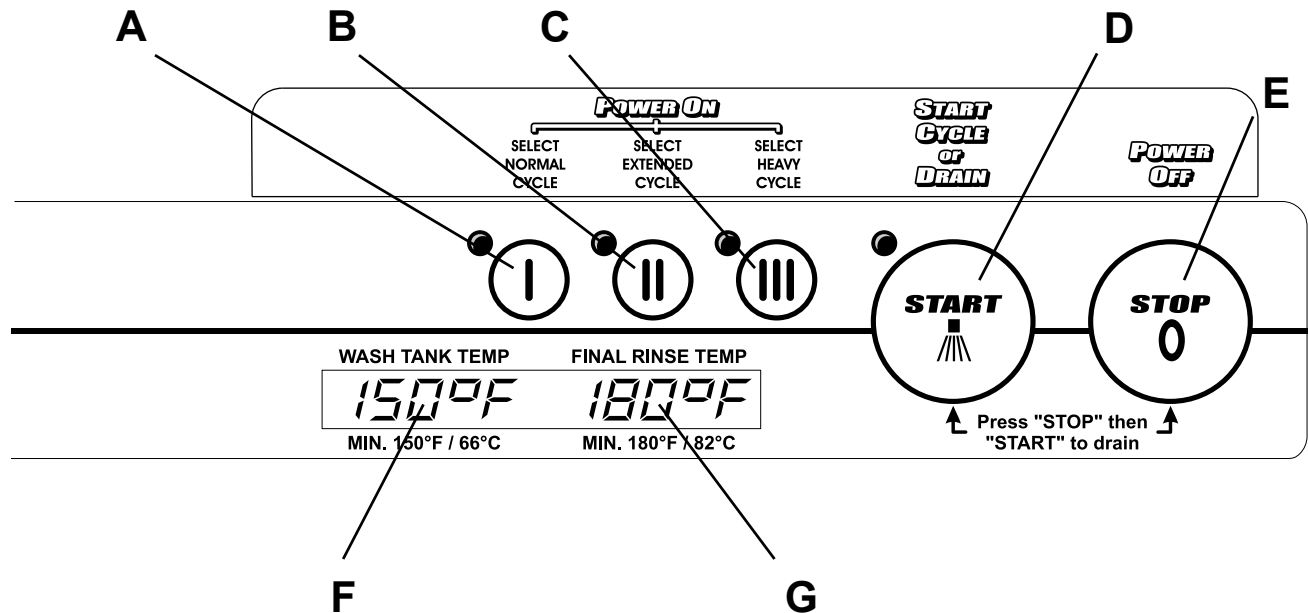

A, B, C - POWER/CYCLE SELECT keys

These keys turn the dishwasher on. Each key selects a different cycle length to accommodate differing levels of soiling:

- **Normal cycle** for typically soiled plates, bowls, etc.
- **Extended cycle** for items with greater soiling
- **Heavy cycle** for very heavily soiled items

The keys may also be pressed between cycles to choose a different cycle length.

D - START/DRAIN key

If pressed when the unit is ready to operate, this key starts the operating cycle. If the dishwasher has been switched off (for instance, at the end of the shift), this key empties the tank.

E - STOP/OFF key



If pressed when the unit is in operation, this key ends the cycle immediately. If the unit is NOT in operation, this key will switch the unit off.

F - WASH TANK TEMP display



Shows the current temperature of the water in the wash tank.

G - FINAL RINSE TEMP display

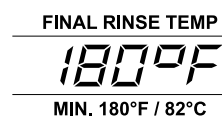



Shows the current temperature of the final rinse water. The dishwasher cannot begin a final rinse cycle until the rinse water has heated to the proper temperature. The wash cycle will automatically extend (if necessary) until the proper rinse temperature is reached.

4.2 Startup

Check the level of the external detergent and rinse additive dispensers. If necessary, replace or refill the dispensers.

Press any of the three POWER/CYCLE SELECT keys to turn on the dishwasher.

-  **Normal cycle** for typically soiled items
-  **Extended cycle** for items with greater soiling
-  **Heavy cycle** for very heavily soiled items

(flashing) The light above the selected POWER/CYCLE SELECT key will begin to flash, showing that the tank is filling and the water is heating to the correct temperature.

The time required for filling and preheating will vary based on the temperature of the incoming water supply. For incoming water at 140°F/60°C, the machine may need up to 15 minutes to fill and heat to the correct wash temperature. The default wash temperature is several degrees above 150°F/66°C for efficient operation.

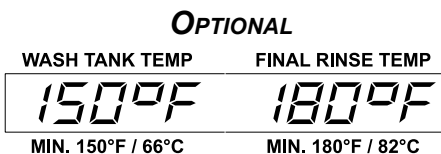

If desired, you can watch the WASH TANK TEMPERATURE and FINAL RINSE TEMPERATURE displays as they rise. This gives an indication of the amount of time left before the dishwasher can be operated.

(constant) When the tank is full and the water has been heated to the correct temperature, the light above the selected POWER/CYCLE SELECT key will stop flashing. The machine is now ready for operation.

4.3 Loading

The loading guidelines shown here will lead to faster, more efficient cleaning of your ware.

Load plates, soup bowls, etc. at an angle with the inside face pointing up. Ensure that water cannot pool in the bottom of bowls.

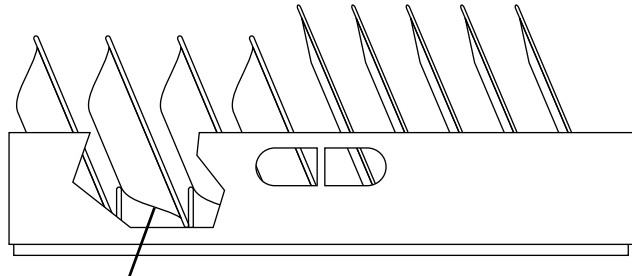

Position bowls to allow water to drain

Load hollow or concave dishware (glasses, large bowls, etc.) upside-down and at an angle. This allows water to drain more quickly, preventing stains.

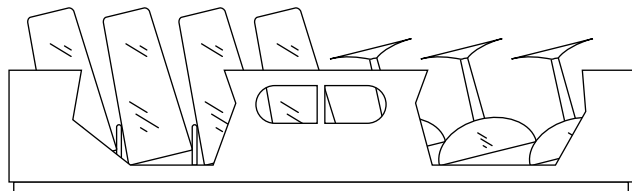

For greater efficiency in loading cutlery, you can use cutlery holders. When loading them:

- Do not overload the holders.
- Always load knives, forks and spoons with the handle DOWN.
- Do not load identical ware into any given holder. Instead, load an assortment of knives, forks and spoons into each holder. Identical ware is often too closely spaced for effective cleaning.

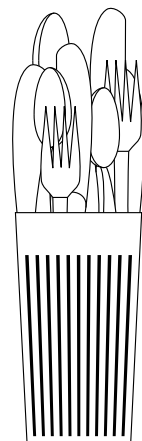

Do not stack items in the dishwasher. Stacked items require longer or multiple cleaning cycles because the wash water cannot reach the food residue as effectively. It is more efficient to load the dishwasher with fewer items and run multiple, shorter cycle times.

4.4 Operation

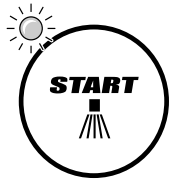

Press the START/DRAIN key to begin the selected cycle. The key will not work unless the light above the selected POWER/CYCLE SELECT key has stopped flashing.

The dishwasher will begin a wash and rinse cycle. The **Soft Start** feature pumps the water through the arms slowly for the first few seconds of the cycle to protect fragile ware. After a few seconds, full pressure will engage.

The time of the total cycle will be at least as long as the times shown on the machine's serial plate. When using a cold water supply, the machine will automatically extend the wash cycle if necessary until the final rinse water can be heated to the correct temperature.

OPTIONAL

If desired, the cycle can be stopped at any time by pressing the STOP/OFF (O) key OR by opening the door.



WARNING!

If the door is opened suddenly, hot water can spray out of the dishwasher. To prevent this from happening:

- *Open the door slowly until the dishwasher stops operating, OR*
- *Press the STOP/OFF (O) key to stop the wash/rinse cycle before opening the door.*

When the cycle has completed, the dishwasher will stop operating and sound a three-stage beeping tone. After the tone has sounded, you may open the door and unload the dishware. Note that steam escapes when the door is opened; this is normal.



WARNING!

Use caution when handling hot dishes, glassware and other items.

4.5 Between Cycles

Between cycles, leave the door of the machine closed. If the door is left open, the wash tank water will cool. This will activate the tank heaters, consuming extra energy, and may lengthen the recovery time when another cycle is started.

If necessary, you can choose a different cycle length between cycles by pressing any of the POWER/CYCLE SELECT keys.

When you are ready to start a new cycle, refer to Section 4.3, "Loading."

4.6 Shutdown



At the end of the shift, press the STOP/OFF key.

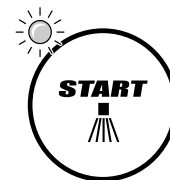

Press the START/DRAIN key to empty the tank.

After the water has drained, the dishwasher will enter a self-cleaning mode. The interior will be sprayed with hot, fresh water as the booster tank empties. When this is completed, the drain will "pulse" several times to empty the water and the dishwasher will automatically shut off.

WARNING!



DO NOT open the door of the dishwasher during the self-cleaning process! The process will be interrupted and hot water may spray out of the dishwasher.

After the dishwasher has finished its self-cleaning cycle, open the door. Remove any food particles, scraps or bones from the scrap screen. MEIKO recommends that the door of the dishwasher be left open overnight to allow it to air thoroughly.

5 CLEANING



WARNING!

Before ANY cleaning, check that the circuit breaker/fused disconnect is in the OFF position and that the unit is switched off.

IMPORTANT

The headings *Daily Cleaning* and *Weekly Cleaning* in this section are general recommendations based on typical soiling.

If soil begins to accumulate, the unit should be cleaned more frequently. Extensive food soil deposits inside the machine work against optimal performance. Some items may not be cleaned as effectively, resulting in the need for either a longer cycle or repeat washing. In addition, heavy soiling in the wash water increases detergent consumption.

5.1 Daily Cleaning (or as required)

1. The dishwasher automatically enters a self-cleaning cycle when it is turned off. The interior will be sprayed with hot, fresh water as the booster tank empties.
2. AFTER this cycle ends and the machine shuts down, open the door. Remove any food particles, scraps or bones from the scrap screen.
3. Lift out the scrap screen and clean it thoroughly using a brush and warm water.
4. Lift out the Active Plus filter. Clean it thoroughly using a brush and warm water. Be sure to use care to avoid damaging the screen on the Active Plus filter.
5. MEIKO recommends that the door of the dishwasher be left open overnight to allow it to air thoroughly.
6. Reassemble all components into the machine before operation. Note the following:
 - The Active Plus filter MUST be reinstalled with the slotted end facing DOWN. See Figure 5-1.
 - The scrap screen MUST be reinstalled so that the round grate lines up with the Active Plus filter. See Figure 5-1.

Figure 5-1: Screen and filter removal

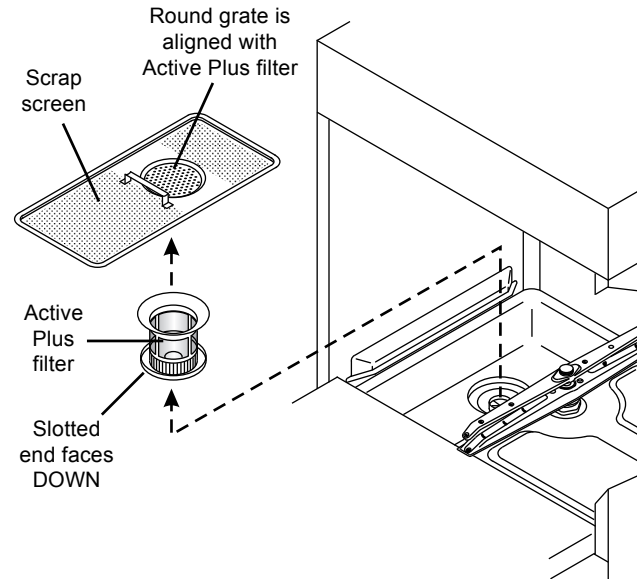

5.2 Weekly Cleaning (or as required)

Once per week, or as required, perform the following steps:

1. Open the door. Remove and clean the scrap screen and Active Plus filter as described in Section 5.1, "Daily Cleaning."
2. Remove and disassemble the arms as shown in Figures 5-2 and 5-3. Clean the arms with a brush and warm running water.
3. Reassemble all components into the dishwasher. Note the following:
 - The Active Plus filter MUST be reinstalled with the slotted end facing DOWN. See Figure 5-1.
 - The scrap screen MUST be reinstalled so that the round grate lines up with the Active Plus filter. See Figure 5-1.
 - The top and bottom wash arms are identical and interchangeable.
 - The rinse arms are NOT interchangeable and MUST be replaced in their original positions. The bottom rinse arm is marked "BOTTOM." The top rinse arm is marked "TOP."

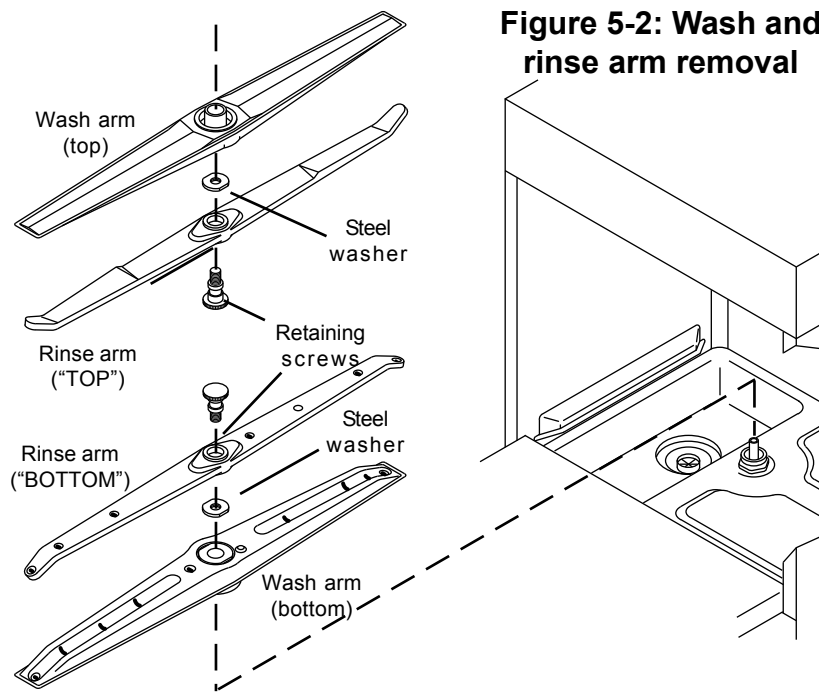
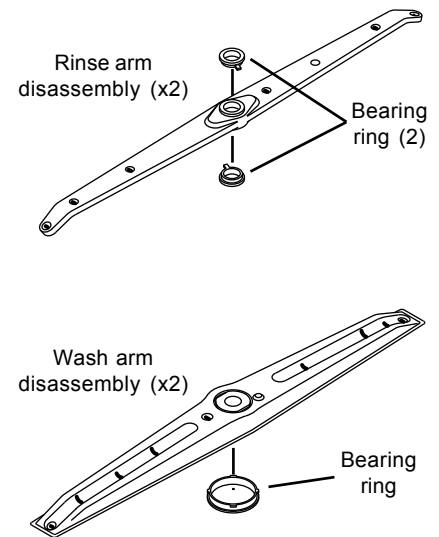

Figure 5-2: Wash and rinse arm removal

Figure 5-3: Wash and rinse arm disassembly



5.3 Exterior cleaning (as required)

CAUTION

When cleaning the exterior of the dishwasher, be sure to follow these guidelines:

- MEIKO strongly recommends using detergent when cleaning the exterior of the unit, instead of commercial stainless steel cleaners. These cleaners can damage the surface of the control panel.
- Never use abrasive cleaners or pads when cleaning the exterior of the dishwasher. These can scratch the surface of the unit.



WARNING!

Ensure that detergents and stainless steel cleaners are kept out of the interior of the dishwasher. If the interior of the unit requires cleaning, refer to the deliming procedures (Section 5.4).

5.4 Deliming (as required)

Lime scale deposits will occur over time on the interior of the dishwasher if it is operated using a hard water supply. MEIKO recommends a hardness of 4-6 grains per U.S. gallon.

A deliming or de-scaling process can be used to remove these deposits, as well as any accumulated food residue.

CAUTION

When deliming the interior, be sure to follow these guidelines:

- Use deliming agents designed for use with commercial dishwashers.
- Follow the instructions for the deliming agent that is used.

After the deliming process:

1. Run the dishwasher through 3-6 regular cycles without a load to rinse and sanitize the interior thoroughly.
2. Inspect the interior for any remaining deliming agent residue. If residue is present, remove it using a soft cloth and hot water; then, run the machine through one final empty cycle.
3. Press the STOP/OFF (O) key; then, press the START/DRAIN key. This will empty the tank, ensuring that any deliming agent still in the tank will be flushed out of the machine.



WARNING!





Ensure that ALL residue of the deliming agent is removed. Residue from the agent can:

- Pose a health hazard;
- Damage seals and plastic components inside the dishwasher.

6 TROUBLESHOOTING

If the dishwasher encounters a problem, an Info Code or Error Code will usually appear in the display. If you use this troubleshooting guide to resolve simple problems, you can often return the appliance to operation faster than by placing a service call.

Info Codes appear for minor difficulties. Error codes appear for more complex issues. After correcting the condition, if the unit does not return to normal operation automatically, press the START/DRAIN () key or the STOP/OFF (**O**) key to clear the message.

<i>Display Shows</i>	<i>Problem</i>	<i>Action</i>
	Tank is not heating OR fresh water is not entering unit	Check that the water hose is correctly attached and is free of “kinks” or pinching. Also check that the water supply is turned on.
	Door is not closed OR door switch is defective	Check that the door is completely closed.
	Water leakage onto floor pan	Check that the water line to the unit is not leaking, and that the drain hose empties correctly into the drain.
	Correct water level was not reached during initial filling	Check that the water hose is correctly attached and is free of “kinks” or pinching. Also check that the water supply is turned on.
	Filling process takes too long	Check that the water hose is correctly attached and is free of “kinks” or pinching. Also check that the water supply is turned on.

You should contact your MEIKO Authorized Service Agent IF:

- ***The dishwasher encounters a problem but does not display an error code, OR***
- ***An error code appears that is not shown here, OR***
- ***The listed action fails to correct the problem.***

An Authorized Service Agency Listing was supplied with your dishwasher. If you do not have the listing, call 1-800-868-3840 for assistance.

If you need service...



MEIKO dishwashers are designed for solid reliability as much as for outstanding ware-cleaning ability. With proper care, your dishwasher should provide years of trouble-free operation.

If service is necessary, contact your local MEIKO Authorized Service Agent. With factory training, OEM parts and direct support from the factory, MEIKO's nationwide service network is highly qualified to quickly restore your dishwasher to regular operation.

An Authorized Service Agency Listing is supplied with this Manual. If you do not have the listing, call 1-800-868-3840 for assistance.



MEIKO
1349 Heil Quaker Blvd.
La Vergne, TN 37086
Phone: (615) 399-6600
(800) 55-MEIKO
Fax: (615) 399-6620