

WELLS BLOOMFIELD, LLC
10 Sunnen Dr., St. Louis, MO 63143
telephone: 314-678-6314
fax: 314-781-2714
www.wellsbloomfield.com

522

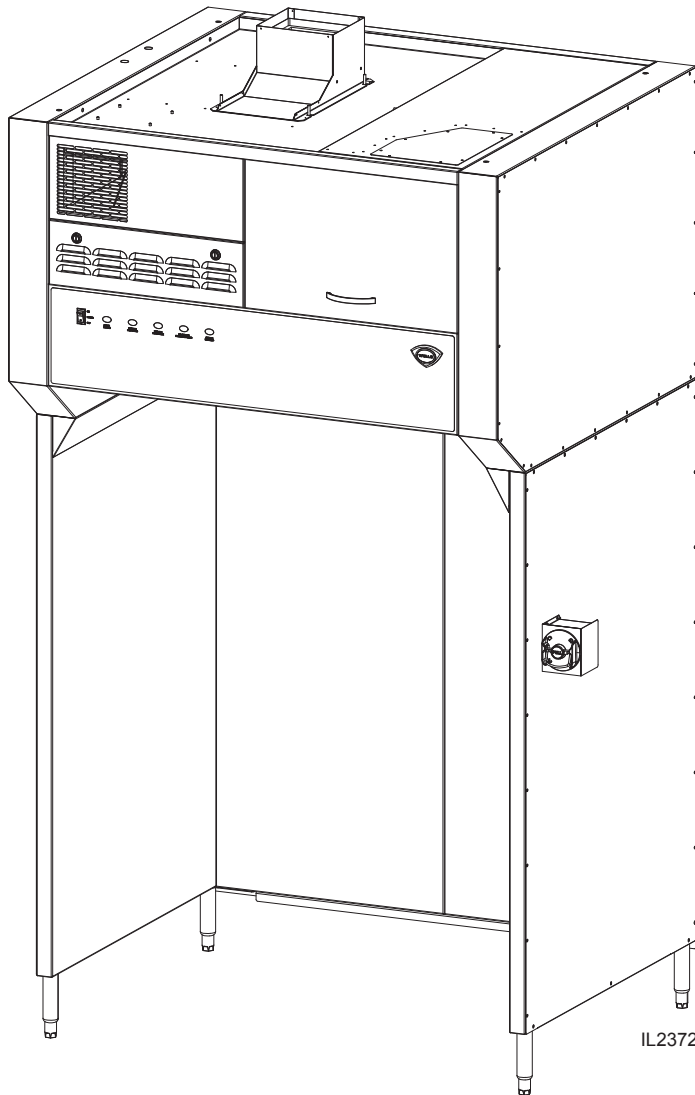

OWNERS MANUAL

**VENTLESS UNIVERSAL
HOOD SYSTEM
for
ELECTRIC
COOKING
APPLIANCES**

**MODEL
WVU48
WVU96**

**Manual Includes
INSTALLATION
USE & CARE
EXPLODED VIEW
PARTS LIST
WIRING DIAGRAM**

IMPORTANT: DO NOT DISCARD THIS MANUAL

This manual is considered to be part of the appliance and is to be given to the OWNER or MANAGER of the restaurant, or to the person responsible for TRAINING OPERATORS of this appliance. Additional manuals are available from your WELLS DEALER.

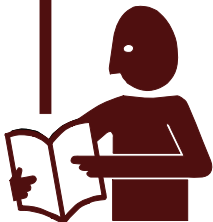

THIS MANUAL MUST BE READ AND UNDERSTOOD BY ALL PERSONS USING OR INSTALLING THIS APPLIANCE. Contact your WELLS DEALER if you have any questions concerning installation, operation or maintenance of this equipment.

LIMITED WARRANTY STATEMENT

Unless otherwise specified, all commercial cooking equipment manufactured by WELLS BLOOMFIELD, LLC is warranted against defects in materials and workmanship for a period of one year from the date of original installation or 18 months from the date of shipment from our factory, whichever comes first, and is for the benefit of the original purchaser only.

THIS WARRANTY IS THE COMPLETE AND ONLY WARRANTY, EXPRESSED OR IMPLIED IN LAW OR IN FACT, INCLUDING BUT NOT LIMITED TO, WARRANTIES OF MERCHANTABILITY OR FITNESS FOR ANY PARTICULAR PURPOSE, AND/OR FOR DIRECT, INDIRECT OR CONSEQUENTIAL DAMAGES IN CONNECTION WITH WELLS BLOOMFIELD PRODUCTS.

This warranty is void if it is determined that, upon inspection by an authorized service agency, the equipment has been modified, misused, misapplied, improperly installed, or damaged in transit or by fire, flood or act of God. It also does not apply if the serial nameplate has been removed, or if service is performed by unauthorized personnel. The prices

charged by Wells Bloomfield for its products are based upon the limitations in this warranty. Seller's obligation under this warranty is limited to the repair of defects without charge by a Wells Bloomfield factory authorized service agency or one of its sub-service agencies. This service will be provided on customer's premises for non-portable models. Portable models (a device with a cord and plug) must be taken or shipped to the closest authorized service agency, transportation charges prepaid, for service. In addition to restrictions contained in this warranty, specific limitations are shown in the Service Policy and Procedure Guide. Wells Bloomfield authorized service agencies are located in principal cities. This warranty is valid in the United States and Canada and void elsewhere. Please consult your classified telephone directory, your foodservice equipment dealer or contact:

Wells Bloomfield, LLC

10 Sunnen Dr., St. Louis MO 63143 USA
phone (314) 678-6314 or fax (314) 781-2714

for information and other details concerning warranty.

SERVICE POLICY AND PROCEDURE GUIDE and ADDITIONAL WARRANTY EXCLUSIONS

1. Resetting of safety thermostats, circuit breakers, over load protectors, and/or fuse replacements are **not** covered by this warranty unless warranted conditions are the cause.
2. All problems due to operation at **voltages or phase other than specified on equipment nameplates** are **not** covered by this warranty. Conversion to correct voltage and/or phase must be the customer's responsibility.
3. All problems due to **electrical connections not made in accordance with electrical code requirements and wiring diagrams** supplied with the equipment are **not** covered by this warranty.
4. Replacement of items **subject to normal wear**, to include such items as knobs, light bulbs; and, normal maintenance functions including adjustments of thermostats, adjustment of micro switches and replacement of fuses and indicating lights are **not** covered by warranty.
5. Damage to electrical cords and/or plug due to exposure to excessive heat are **not** covered by this warranty.
6. Full use, care, and maintenance instructions supplied with each machine. Noted maintenance and preventative maintenance items, such as servicing and cleaning schedules, are customer responsibility. Those miscellaneous adjustments noted are customer responsibility. Proper attention to preventative maintenance and scheduled maintenance procedures will prolong the life of the appliance.
7. Travel mileage is limited to **sixty (60) miles** from an Authorized Service Agency or one of its sub-service agencies.
8. All labor shall be performed during regular working hours. Overtime premium will be charged to the buyer.
9. All genuine Wells replacement parts are warranted for ninety (90) days from date of purchase on non-warranty equipment. This parts warranty is limited only to replacement of the defective part(s). **Any use of non-genuine Wells parts completely voids any warranty.**
10. Installation, labor, and job check-outs are **not** considered warranty and are thus **not** covered by this warranty.
11. Charges incurred by delays, waiting time or operating restrictions that hinder the service technician's ability to perform service are **not** covered by warranty. This includes institutional and correctional facilities.

SHIPPING DAMAGE CLAIM PROCEDURE

NOTE: For your protection, please note that equipment in this shipment was carefully inspected and packaged by skilled personnel before leaving the factory. Upon acceptance of this shipment, the transportation company assumes full responsibility for its safe delivery.

IF SHIPMENT ARRIVES DAMAGED:

1. **VISIBLE LOSS OR DAMAGE:** Be certain that any visible loss or damage is noted on the freight bill or express receipt, and that the note of loss or damage is signed by the delivery person.
2. **FILE CLAIM FOR DAMAGE IMMEDIATELY:** Regardless of the extent of the damage.

3. **CONCEALED LOSS OR DAMAGE:** if damage is unnoticed until the merchandise is unpacked, notify the transportation company or carrier immediately, and file "CONCEALED DAMAGE" claim with them. This should be done within fifteen (15) days from the date the delivery was made to you. Be sure to retain the container for inspection.

Wells Bloomfield cannot assume liability for damage or loss incurred in transit. We will, however, at your request, supply you with the necessary documents to support your claim.

TABLE OF CONTENTS

WARRANTY	xi
ELECTRICAL SPECIFICATIONS	1
FEATURES □ OPERATING CONTROLS	2-3
PRECAUTIONS □ GENERAL INFORMATION	4
AGENCY LISTING INFORMATION	5
INSTALLATION	5
Unpacking & Inspection	5
Components	5
Under-Hood Appliance Limitations	6
Service Technician Installation Notes	7
Base Assembly	8-9
Electrical Installation	10-11
ANSUL □ INSTALLATION □ SETUP	12-13
Filter Installation	14
OPERATION	15
Operation Lights	15
CLEANING INSTRUCTIONS	16-17
REQUIRED MAINTENANCE □ MAINTENANCE LOGS	16-23
TROUBLESHOOTING SUGGESTIONS	24
WIRING DIAGRAM	25
EXPLODED VIEW □ PARTS LIST	27-36
PARTS □ SERVICE	37
CUSTOMER SERVICE DATA	37

INTRODUCTION

Thank You for purchasing this Wells Bloomfield appliance.

Proper installation, professional operation and consistent maintenance of this appliance will ensure that it gives you the very best performance and a long, economical service life.

This manual contains information and instructions for the ventless ventilation hood, its use and care.

For information regarding cooking appliance(s), please refer to the manufacturer's operation manual.

ELECTRICAL SPECIFICATIONS

Model	Volts	Amps	Power Supply
WVU48	208/240V	3.5	For supply connection use #12 AWG copper wire only.
WVU96		8.0	

FEATURES & OPERATING CONTROLS

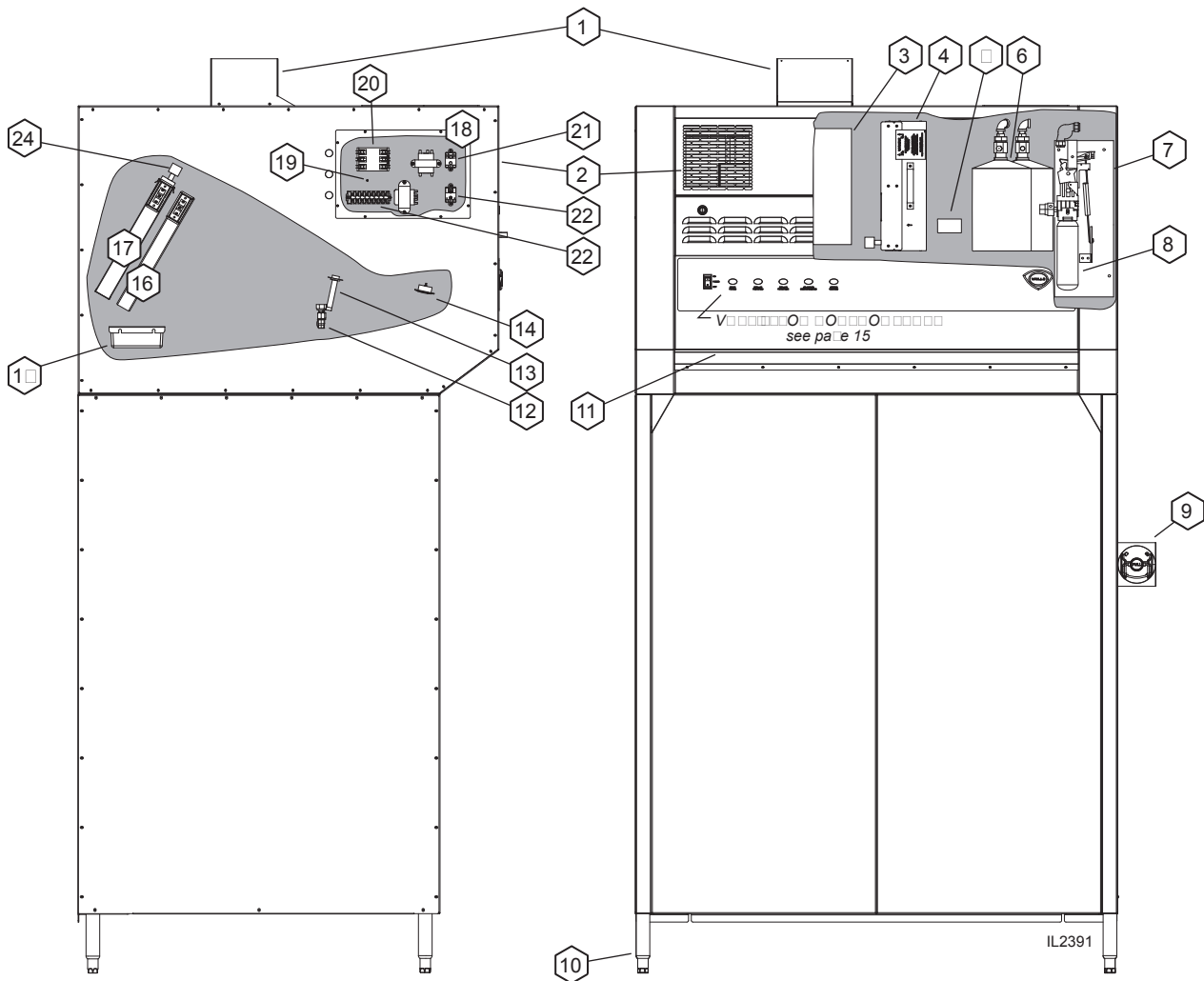

Ventilator Operation Features Controls

IL2391

FEATURES & OPERATING CONTROLS continued

FEATURES & OPERATION CONTROLS		
ITEM NO	DESCRIPTION	COMMENT
1	VENTILATOR EXHAUST DUCT, TOP	Exit point for ventilator airflow - on top of unit. DO NOT BLOCK
2	VENTILATOR EXHAUST DUCT, FRONT	Exit point for ventilator airflow - on front of unit. DO NOT BLOCK
3	VENTILATOR FAN	Provides air movement for ventilation
4	HI-EFFICIENCY/CHARCOAL FILTER PACK	Removes grease and smoke particles. Also assists in cooking odor removal.
5	NAMEPLATE	Gives manufacturer, make and model description. Also list voltage and amperage data.
6	FIRE SUPPRESSION TANK	Container for ANSUL® Low-pH Liquid fire suppression fluid.
7	ACTUATOR ASSY	Triggers deployment of suppression fluid through manual pull station or electric detection.
8	ANSUL® CARTRIDGE	Propels suppression liquid through suppression manifold and nozzles.
9	MANUAL PULL STATION	Provides a means of manual activation of the fire suppression system. PULL ONLY IN CASE OF FIRE!
10	ADJUSTABLE LEGS	Allows the unit to be leveled.
11	AIR WALL	A wall of air that moves the grease and smoke particles into the filter system.
12	DISCHARGE NOZZLES	Fire suppression media discharges here, (6 places 48", 12 places 96")
13	ELECTRICAL DETECTORS	Designed to activate at certain temperature. Activates (i.e. fire on the cooktop) activates fire suppression system. Should be checked every 6 months during ANSUL® Service Inspection
14	APPLIANCE LIGHT	ON when hood power switch is ON. Illuminates cooking area.
15	GREASE DRIP TRAY	Collects grease/moisture dripping from baffle filter (16)
16	BAFFLE FILTER	Extracts and drains most greases and moisture from the air flow.
17	PRE-FILTER ASSEMBLY	Comprises the PRE-FILTER FRAME and a replaceable PRE-FILTER. Stops large particles of grease from reaching the FILTER PACK for reduced maintenance costs.
18	ELECTRICAL CONNECTION BOX	Houses electrical components
19	GROUND LUG	Ground wire of power connection connects here.
20	EQUIPMENT INTERFACE CONTACTOR	Energizes cooking appliances only while ventilator section is sensed as operational.
21	BUILDING FIRE ALARM RELAY	Reports fire alarm condition to building fire management system.
22	DETECTION END OF LINE RELAY	Prevents appliance operation if a fault is found in detection circuit.
23	SUPPLY CONNECTION TERMINAL BLOCK	Provides connection point for electrical circuitry
24	FILTER INTERLOCK SWITCHES	Proper installation of baffle filter and filter pack closes these switches in ventilator sensor circuit

PRECAUTIONS AND GENERAL INFORMATION



DANGER: **SUFFOCATION HAZARD**

Do not attempt to use this ventilator with gas-fired units. This ventilator will not remove products of combustion. Unvented exhaust gasses can be deadly.



WARNING: **SHOCK HAZARD**

All servicing requiring access to non-insulated electrical components must be performed by a factory authorized technician.

DO NOT open any access panel which requires the use of tools. Failure to follow this warning can result in severe electrical shock.

IMPORTANT:

The ventilator is disabled when the filters are plugged to the point of insufficient airflow for proper operation. Also, power to the cooking appliances is interrupted if any filters or service panel are removed.

It is the responsibility of the store management to maintain sufficient spares of filter packs to avoid prolonged shutdown due to a dirty or clogged filter pack. Filter packs cannot be cleaned.

Wells Bloomfield assumes no liability for loss of business due to a filter related shutdown. Spare filters can be purchased from any authorized Wells servicer or calling Wells.

This ventilator hood is part of an engineered system and is intended for use in commercial establishments only.

This ventilator is intended for commercial establishments for use in the preparation food for human consumption. No other use is recommended or authorized by the manufacturer or its agents.

Operators of this appliance must be familiar with the appliance use, limitations and associated restrictions. Operating instructions must be read and understood by all persons using or installing this appliance.

This ventilator hood system is designed to reduce odor emissions, but will not completely eliminate all cooking odors. Air exchange rates at the installation site must comply with the requirements of the local jurisdictional authority. To ensure that odors do not accumulate, recommended minimum air exchange is 200 cfm per linear foot of hood into and out of the site.

This unit is intended for use with light- and medium duty electric cooking appliances only. Cooking appliances placed under this ventilator must comply with the restrictions set forth in the *Installation Instructions Manual*.

Do not connect or energize this appliance until all installation instructions are read and understood. Property damage or bodily injury may result if these instructions are not followed. Disconnect this appliance from electrical power before performing any maintenance or servicing.

Cleanliness of this appliance is essential to good sanitation. Read and follow all included cleaning instructions and schedules to ensure the safety of the food product.

This appliance is not jet steam approved. Do not direct water jet or steam jet at this appliance, or at any control panel or wiring. Do not splash or pour water on, in or over any controls, control panel or wiring. Do not attempt to wash filter packs. Water will cause their immediate failure and disable the ventilator.

Exposed surfaces of this appliance can be hot to the touch and may cause burns.

Avoid storing flammable or combustible materials in, on or near the ventilator or associated cooking appliance.

The technical content of this manual, including any wiring diagrams, schematics, parts breakdown illustrations and/or adjustment procedures, is intended for use by qualified technical personnel.

Any procedure which requires the use of tools must be performed by a qualified technician.

All supplied instructions, diagrams, schematics, parts breakdown illustrations, notices and labels must remain with the appliance if the unit is sold or moved to another location.

This appliance is made in the USA. Unless otherwise noted, this appliance has American sizes on all hardware.

AGENCY LISTING INFORMATION

SANITATION



NSF/ANSI 2



UL710B

Recirculating System

This appliance conforms to NSF Standard 2 for sanitation only if installed in accordance with the supplied *Installation Instructions* and operated and maintained in accordance with the instructions in this manual.

UL CLASSIFIED for use in US and Canada

INSTALLATION

UNPACKING & INSPECTION

Carefully remove the appliance from the carton. Remove all protective plastic film, packing materials and accessories from the appliance before connecting electrical power or otherwise performing any installation procedure.

Carefully read all instructions in this manual and any other documents packed with the appliance before starting any installation. All documentation should remain with the equipment operator for future reference.

Read and understand all labels and diagrams attached to the ventilator.

Carefully account for all components and accessories before discarding packing materials.

COMPONENTS

	4 ft	8 ft
Pre-Filter	2 ea.	4 ea.
Baffle Filter	2 ea.	4 ea.
Filter pack	1 ea.	2 ea.
Grease cup	1 ea.	2 ea.

Ansul® components - must be installed by an authorized Ansul® distributor only:

	4 ft	8 ft
2 ea.	4 ea.	Fire suppression agent tank
2 ea.	4 ea.	Fire suppression agent (Ansulex® Low pH) 1.5 gal.
1 ea.	2 ea.	Fire suppression system charging cartridge

Store these components in a convenient place for later use.

The unit is shipped configured for horizontal discharge of the exhaust. To convert to vertical discharge:

1. Remove top access cover.
2. Remove internal turning vane.
3. Insert top discharge scoop assy and fasten w/hardware from cover.
4. Remove front discharge vent panel and damper assy.
5. Assemble damper in Top discharge scoop assy.
6. Replace front discharge vent panel.

NOTE: DO NOT discard the carton or other packing materials until you have inspected the appliance for hidden damage and tested it for proper operation.

Refer to **H** **M** **M** **O** **U** on the inside front cover of this manual.



WARNING: RISK OF INJURY

Installation procedures must be performed by a qualified technician with full knowledge of all applicable electrical codes. Failure can result in personal injury and property damage.

IMPORTANT:

Fire suppression system must be charged and certified by an authorized Ansul® distributor. Ventilator will not operate and cooking appliance will not be energized until the Ansul® fire suppression system has been charged.

IMPORTANT:

After cooking appliances are positioned under the hood, swivel nozzles must be positioned per Ansul® recommendations.

INSTALLATION (continued)

UNDER-HOOD APPLIANCE LIMITATIONS:

1. Appliance must be installed per manufactures instructions.
2. Electrical appliances only. Not Intended for gas fired units.
3. All appliances under the hood must be connected to the hood appliance interlock circuit.
4. All appliances must meet the requirements outlined in the cooking appliance limitations chart below.

COOKING APPLIANCE LIMITATIONS							
Coverage Parameters	Max kW / Ft	Max Cooking Temp	Max Single Units Cooking Surface	Dim "A" (3) Minimum	Dim "B" (4) Minimum	Dim "B" (4) Maximum	Dim "C" (5) Minimum
Fryer	16.9	400°F	18	14	37	42	0
Griddle	5.5	450°F	36	21	37	42	1
Range/Hotplate	5.5 (2)	n/a	48	21	37	42	1
Wok	7	n/a	48	21	37	42	0
Oven	n/a	550°F	48	6	8	n/a	0
Braising Pan / Skillet (1)	7.2	450°F	48	14	37	42	0
Convection Oven	n/a	550°F	48	6	8	n/a <td 0	
Steamer / Combi Oven	n/a	550°F	48	6	8	n/a	0

- (1) Lid must not interfere with suppression nozzle discharge pattern.
- (2) Plus oven kW if applicable.
- (3) Front of hood to front edge of heated cooking surface.
- (4) Bottom front edge of hood to height of heated cooking surface.

Intended for installation in accordance with:

The standard for ventilation control and fire protection of commercial cooking operations NFPA 96, the National Electric Code NFPA 70 and local codes where applicable.

Only electrically heated appliances are acceptable for installation. Appliance Operation Requires the Fire suppression system be setup, charged and certified by an authorized ANSUL distributor. The airflow monitoring system will prevent appliance operation if insufficient airflow is detected or all filters are not in place. The service panel must be in place for blower operation.

Option 1 - 12" vertical clearance increases the overall vertical clearance

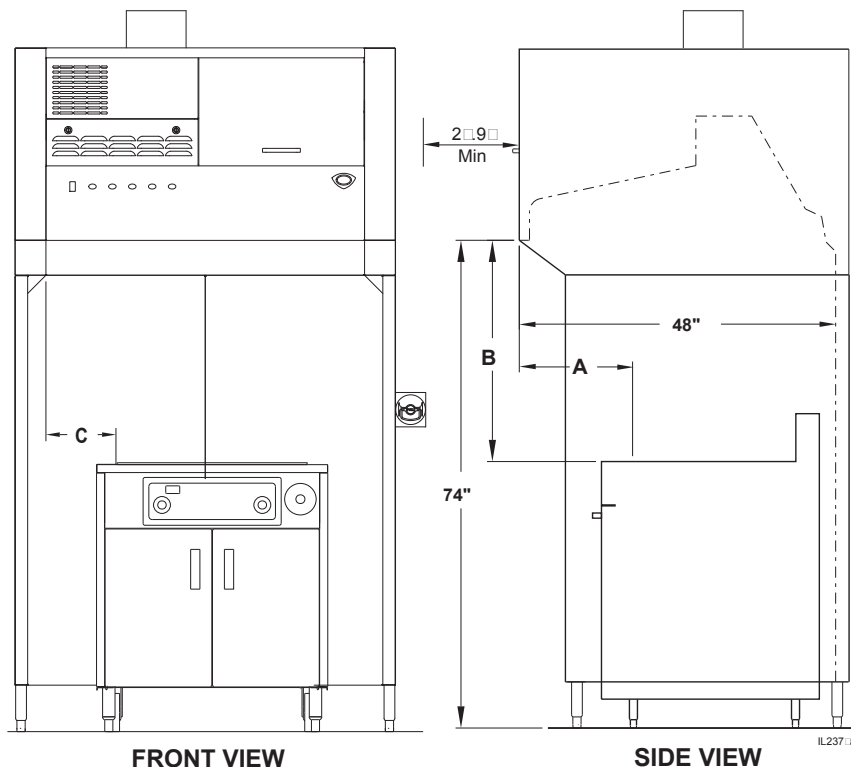

INSTALLATION (continued)

SERVICE TECHNICIAN INSTALLATION NOTES

This ventilator hood is to be used with light-duty and medium-duty electrically powered cooking appliances only.

- DO NOT attempt to use this ventilator hood with gas-fired units.
- DO NOT use this ventilator hood with electrical appliances whose dimensions or wattage characteristics exceed those defined in the Under Hood Cooking Appliance Limitations, page 6.

Installation and start up must be performed by an Authorized Installation Company.

Ansul[®] Installer must complete the WARRANTY INITIATION form 2M-1212 included in the manual or the arrangement order, and record installation particulars on the CUSTOMER SERVICE DATA form located at the end of this manual.

IT IS THE RESPONSIBILITY OF THE INSTALLER TO verify that this VENTILATOR installation is in compliance with the specifications listed in this manual, with local code requirements, and in accordance with N.F.P.A 96 the STANDARD FOR VENTILATION CONTROL AND FIRE PROTECTION OF COMMERCIAL COOKING OPERATIONS.

NOTE: Certain codes require FRYERS to be restrained with a TETHER or other RESTRAINT DEVICE. If this ventilator is to be used with a fryer, it is the RESPONSIBILITY OF THE INSTALLER to check with the AUTHORITY HAVING JURISDICTION, in order to ascertain the applicability of this requirement to this specific installation.

SETUP

Setup the appliance only on a firm, level, non-combustible surface. Verify local codes for requirements. Concrete, tile, terrazzo or metal surfaces are recommended. Metal over combustible material may not meet code for non-combustible surfaces.

Verify vertical clearances. Ceiling height shall be no less than 103" inches when utilizing horizontal discharge option. Ceiling height shall be no less than 120" inches when utilizing vertical discharge option.

Verify that the unit sits firmly on ALL LEGS. With a spirit level, check that the appliance is level front-to-back and side-to-side. With the adjustable legs, adjust as required to level the appliance. In order to prevent tipping or deflection, legs must be adjusted such that all legs are in firm contact with the floor.



DANGER: SUFFOCATION HAZARD

Do not attempt to use this ventilator with gas-fired units. This ventilator will not remove products of combustion. Unvented exhaust gasses can be deadly.



WARNING: SHOCK HAZARD

All servicing requiring access to non-insulated electrical components must be performed by a factory authorized technician.

DO NOT open any access panel which requires the use of tools. Failure to follow this warning can result in severe electrical shock.



CAUTION: RISK OF DAMAGE

DO NOT connect or energize this appliance until all installation instructions are read and followed. Property damage or bodily injury could result if these instructions are not followed.

IMPORTANT:

If a remote pull station is to be used, ventilator cannot be moved without first disabling the remote pull station.

Contact your Ansul[®] agent for details.

INSTALLATION (continued)

Hardware Provided

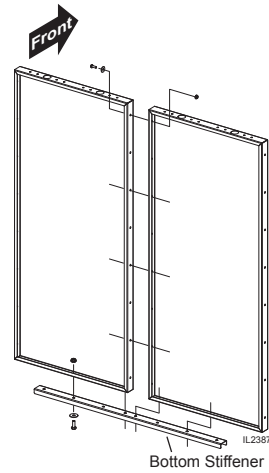
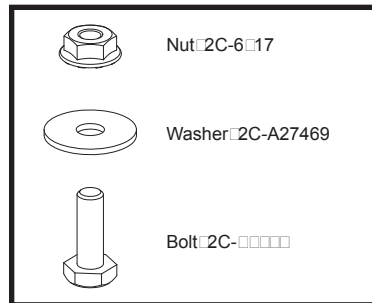

Figure 1

BASE ASSEMBLY

Prior to assembling the base, locate it as close to the final position as possible. Then follow these steps.

1. Align the two rear panels (Fig 1) and secure with a bolt, washer and nut (8 places).
2. Place the Base Bottom Stiffener (N1-Z15330) to the bottom of the two rear panels and secure with bolt, washer and nut (8 places).
3. Align the left and right side of the base to the rear panel (Fig 2) and secure with bolt, washer and nut (8 places each side).
4. Align the rear corner brackets in place (Fig 3) and secure with bolt, washer and nut (4 places each bracket).
5. Install the 6" adjustable legs and secure in place with the bolt provided.

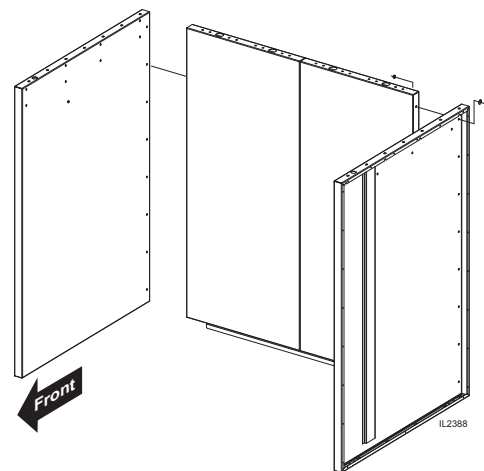

Figure 2

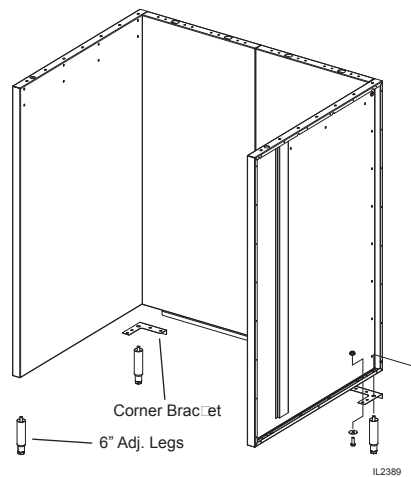

Figure 3

INSTALLATION



DANGER: SUFFOCATION HAZARD

Do not attempt to use this ventilator with gas-fired units. This ventilator will not remove products of combustion. Unvented exhaust gasses can be deadly.



WARNING SHOCK HAZARD

Electrical connections must be made by a licensed electrician.



CAUTION: FIRE HAZARD HEALTH HAZARD

All cooking appliance must be connected to the cooking appliance contactor, the control circuit of which is controlled by the ventilator.

Failure to control cooking appliances will provide no protection in the event of a fire, nor will cooking vapors and odors be contained in the event of ventilator hood

ELECTRICAL INSTALLATION

Refer to the nameplate on the ventilator. Verify ELECTRICAL SERVICE POWER. Voltage and phase must match the nameplate specifications, and available electrical service amperage must meet or exceed the listed amperage. Refer to specifications listed on page 1 of this manual.

The ground lug of this ventilator must be connected to a suitable building ground.

Remove the left side panel to access the cooking appliance contactor and building alarm relay. Remove the appropriate knockout, then wire the cooking appliance control circuit to the terminal block per Fig below.

NOTE: It is the responsibility of the electrical contractor to provide suitable wiring, flexible or rigid conduit, and an appropriate strain relief.

Electrical Connection

NOTE: The hood requires a single phase (1ph), 208 or 240 volt, 20 amp supply. When connecting line voltage to the unit's terminal block, use a minimum of #12 gage copper wire only, suitable for 167°F (76°C) ambient temperature.

Appliance Connections

All under hood appliances are required to be interlocked with the hood's equipment cut-off circuit, through a customer supplied contactor. This contactor must be a UL listed, definite purpose AC resistive air heating type, suitable for the appliance load. Installation and connections shall be in accordance with the National Electric Code NFPA 70. These connections provide an automatic shutdown of the appliance when the hood is OFF, or in the event of a malfunction or appliance fire.

Equipment Cutoff Connections

- Opt 1: Use TB#3 & TB#4 for 208 or 240 volt control circuit. These contacts will be de-energized when the hood is OFF or in the event of a malfunction
- Opt 2: Use TB#5 & TB#6 as a Normally Closed SPST relay connection for equipment control circuits with voltages other than 208 or 240 AC. These contacts will be open when hood is OFF or in the event of a malfunction.

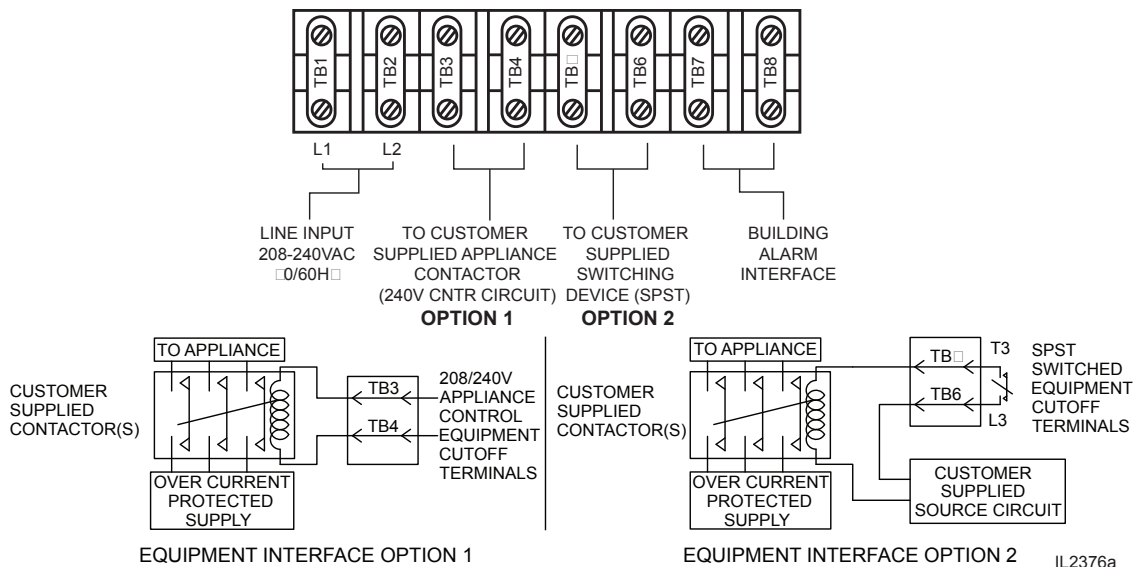

IL2376a

INSTALLATION continued

SUPPLY POWER INSTALLATION

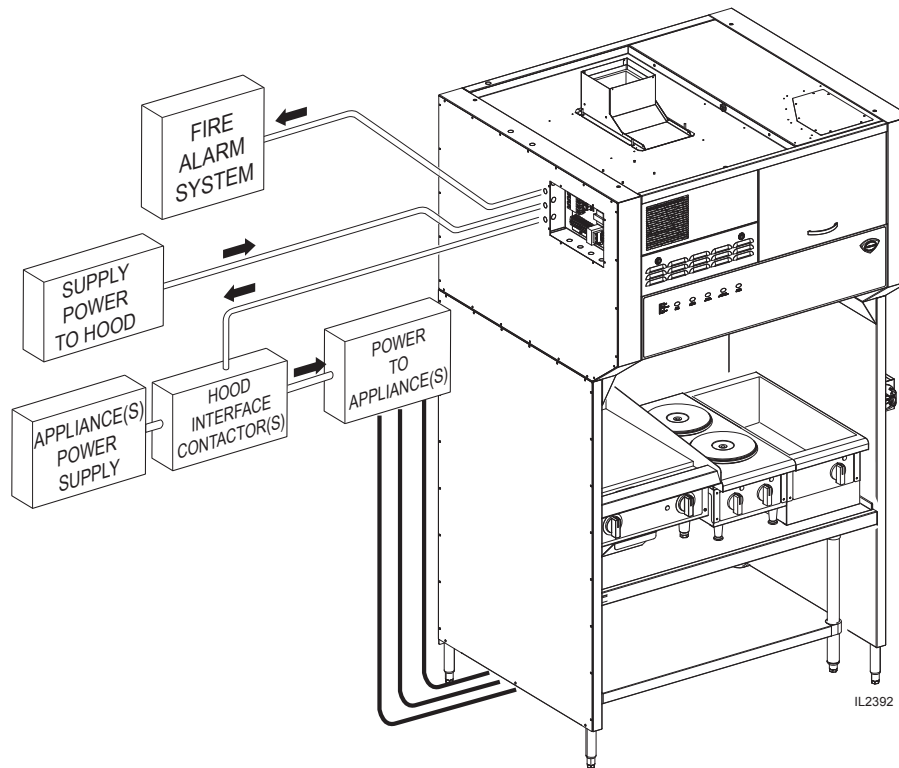

DANGER: SHOCK HAZARD

Turn power off to the unit before removing the side electrical box cover.



CAUTION: SHOCK HAZARD

The ground lug of this appliance must be connected to a suitable building ground.

IMPORTANT:
Contact a licensed electrician to install and connect electrical power to the appliance.

IMPORTANT:
Damage due to being connected to the wrong voltage or phase is NOT covered by warranty.

INSTALLATION continued



Fire suppression system must be charged and certified by an authorized Ansul distributor.

DO NOT attempt to modify or bypass the fire suppression system.

An uncontrolled fire can cause serious injury or death.

NOTE:

If the fire suppression system is discharged, a buzzer will sound continuously. The unit will remain inoperable until the fire suppression system is serviced, recharged and reset by an authorized Ansul distributor.

Charging of the Ansul Fire Suppression system must be in accordance with Ansul Design, Installation, Recharge and Maintenance Manual, 418087.

NOTE:

If a REMOTE MANUAL PULL STATION is installed, moving the ventilator for any reason may cause the Ansul system to discharge.

IMPORTANT:

Should the fire suppression system discharge: all nozzles must be replaced, and all lines thoroughly cleaned, prior to recharging the system.

Residual fire suppression media may compromise the flow and dispersion of fire suppression media in any subsequent activation.

The alarm relay is activated by the Ansul® fire detection system. If the installation includes a building alarm system, connect to terminals T7 or T8 of the terminal block in supply connection box. These terminals are configured from the factory for normally open operation.

The ventilator will operate properly, and the appliance control relay will be energized, only when:

1. The VENTILATOR POWER SWITCH is "ON".
2. The Ansul Fire Suppression System is charged and armed.
3. All filters are in position and serviceable, and the ventilator air flow system is satisfied.

FIRE SUPPRESSION SYSTEM INSTALLATION

EACH 4' FOOT SECTION OF THE FIRE SUPPRESSION SYSTEM is comprised of two containers of Ansul® Low pH liquid fire suppression media and a system pressurization canister, plus associated plumbing. Actuation controls are contained in the Automan enclosure.

The hood is supplied with a field installed MANUAL PULL STATION, which must be set-up at the time of installation by an authorized Ansul distributor.

The MANUAL PULL STATION allows for manual emergency shutdown of cooking appliance power, and actuation of the fire suppression system.

Six WVU4 or twelve WVU6 NOZZLES disperse the fire suppression media. Two inner nozzles protect the fan and plenum. The appliance nozzles are swivel mounted, and must be directed toward the cooking surface of the installed cooking appliance.

If the ventilator is situated such that the supplied manual pull station cannot be installed or is not readily accessible, a REMOTE MANUAL PULL STATION may be required by local codes. Any such remote manual pull station must be installed by an authorized Ansul distributor in accordance with the AUTHORITY HAVING JURISDICTION.

The fire detection system utilizes six WVU4 or twelve WVU6 electronic thermal detectors with an actuation set point of 225°F (17) in the upper hood locations and 275°F (15) detectors in the lower wall locations. The signaling from any of these detection devices will automatically discharge the fire suppression media through all nozzles, disable the cooking appliances and cause the alarm to sound.

Fire suppression media will form an emulsion designed to both smother and cool the fuels in/on the cooking appliance.

INSTALLATION

FIRE SUPPRESSION SYSTEM INSTALLATION (continued)

The MANUAL PULL STATION and any similar REMOTE MANUAL

PULL STATION will activate the fire suppression system when the ring on the pull station is pulled to its full extent.



DANGER
BURN HAZARD

Any additional remote pull station must **NOT** be installed on the front of the cooking appliances,

Discharge of the fire extinguishing system into hot grease or oil may cause hot foam to spill over from the cooking surface or frypot.

Serious burns and other injuries can result from contact with hot oil and from slipping in spilled oil.

The manual pull station is installed on the right side (facing the unit). It may, however, be relocated to the left side of the ventilator hood by an authorized Ansul[®] agent.

INSTALLATION

NOTE:

The BAFFLE FILTERS, PRE-FILTERS and FILTER PACK actuate position switches when they are properly positioned. They must be properly installed for the under hood cooking appliance contactor to be energized.

WARNING SLIP AND FALL HAZARD

DO NOT operate any grease-producing cooking appliance

(e.g. fryer or griddle) unless the grease cup is properly installed. Oil will drip onto floor creating a slipping hazard.

CAUTION BURN HAZARD

DO NOT operate any cooking appliance unless the grease cup is installed.

Moisture dripping onto hot surfaces, oil or grease can cause splattering.

FILTER INSTALLATION

Note air flow direction arrow on filter pack. Remove old filter pack and slide new filter pack fully into the appropriate slot. Verify that the airflow arrow points toward the fan.

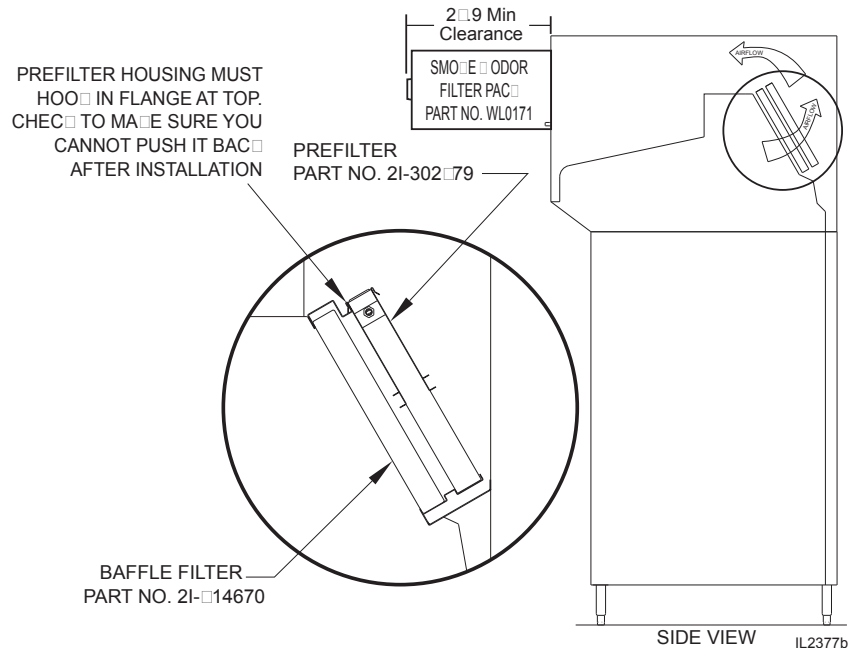

Baffle filters are reusable and should be cleaned at least weekly. Change pre-filters and smoke/odor filter pack as indicated on the front panel. These filters are disposable and cannot be reused. The smoke / odor filter pack is accessed thru the front service door.

Pre-filters are located behind the baffle filters, when installing pre-filters engage top retaining flange prior to seating pre-filter housing in lower chamber.

Use only genuine Wells replacement parts and filters, call (314) 678-6314 or your authorized Wells service agent. Parts supplied by others will void your warranty and may not provide safe operation.

BAFFLE FILTER and GREASE CUP INSTALLATION

1. Install baffle filter from front. Engage the baffle filter in the retainer slot. Push up until the baffle filter bottom clears the lower lip of the retainer, then lower the baffle filter into the bottom retainer
2. Install GREASE CUP into brackets below the baffle filter.

Note: Failure to install the GREASE CUP will allow grease and moisture from the BAFFLE FILTER to drop into hot cooking surfaces, creating both a SAFETY HAZARD (hot oil splatter) and a HEALTH HAZARD (contamination of the cooking surface or cooking oil).

OPERATION

Control Panel

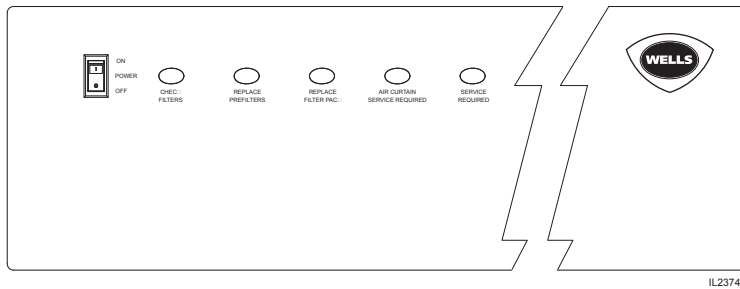

NOTE: Cooking appliances must be operated in accordance with the manufacturer's instructions.

During normal operation, the illuminated power switch will be the only light on the control panel that will be ON.

If the CHECK FILTERS light illuminates, check BAFFLE FILTERS, PREFILTERS, and the HEPA AIR FILTERS for proper installation.

If the REPLACE PRE-FILTERS light illuminates .. Replace the Pre-filters.

If the REPLACE FILTER light illuminates, replace the FILTER PAC.

NOTE: the REPLACE FILTERS light is a warning that filter pack is nearing the end of its service life. The ventilator will continue to operate for a period of time after the REPLACE FILTER LIGHT turns ON to allow continued operation through a peak period. However, filter pack must be replaced within a short time period or it will clog, disabling the ventilator and appliances.

If the SERVICE REQUIRED light illuminates, the filter pack is restricted to the point of insufficient airflow for proper operation and the Ventilator will shut down until the underlying clogged filter situation has been corrected. Replace clogged item with a fresh filter to correct the condition. Reset the unit by turning VENTILATOR POWER SWITCH to OFF, then back to ON.

If the air curtain service required lights illuminate, there is insufficient airflow for proper operation. Call an authorized Wells Service Agent.

A failure of incoming electric power will cause a shut down of the unit. Reset the unit by turning VENTILATOR POWER SWITCH to OFF, then back to ON.

Operation Lights

There are three (WVU48) equipment lights and six on the (WVU96) that provide illumination of the working area. These lights are controlled by the main power switch.



CAUTION: HOT SURFACE

Exposed surfaces can be hot to the touch and may cause burns.



CAUTION: SHOCK HAZARD

DO NOT splash or pour water or grease onto control panel or wiring.

IMPORTANT:

The ventilator cannot operate if the filter pack is removed or clogged.

It is the responsibility of the store management to maintain sufficient spares of filter packs to avoid prolonged shutdown of the ventilator when this filter is expended.

Filter packs cannot be cleaned.

Wells Bloomfield, LLC assumes no liability for loss of business due to filter related shutdown.

Filters that are not genuine Wells Replacement Parts may cause your unit to operate incorrectly and you will risk the possibility of voiding your warranty.

CLEANING INSTRUCTIONS



CAUTION: HOT SURFACE

Exposed surfaces can be hot to the touch and may cause burns. Allow unit to cool before cleaning.



CAUTION: SHOCK HAZARD

DO NOT splash or pour water or grease onto control panel or wiring.

PRECAUTIONS: Disconnect unit from electric power and allow to cool
Cover frypot to prevent oil contamination

FREQUENCY: Weekly

TOOLS: Mild detergent, clean non-abrasive towels

NOTE: Ventilator section to be cleaned in conjunction with cooking appliance. Refer to appliance user instructions for cleaning procedure.

1. TURN HOOD POWER SWITCH TO OFF.
Cover cooking appliance to prevent oil contamination.
2. Remove BAFFLE FILTERS and GREASE CUP(s).
3. Empty GREASE CUP(s) into an appropriate grease collection receptacle.
4. Clean BAFFLE FILTERS and GREASE CUP(s) in a sink or dishwasher using mild detergent and warm water.
5. Dry components with a clean non-abrasive cloth. Reinstall BAFFLE FILTERS and GREASE CUP(s) in ventilator.
6. Wipe exterior of ventilator with a clean cloth moistened with warm water and mild detergent. Rinse by wiping with a clean cloth moistened with warm water.
7. Uncover the cooking appliance and reconnect unit to electric power.

Procedure is complete

CLEANING INSTRUCTIONS

PRECAUTIONS: Disconnect unit from electric power and allow to cool
Cover cooking surfaces and frypots to prevent contamination.

FREQUENCY: Monthly

TOOLS: Mild detergent, clean non-abrasive towels

NOTE: Ventilator section to be cleaned in conjunction with cooking appliance. Refer to appliance user instructions for cleaning procedure.

1. TURN HOOD POWER SWITCH TO OFF.
Cover cooking appliance to prevent oil contamination.
2. Remove BAFFLE FILTERS, GREASE CUP(s), and all FILTER PACK(s).
3. Wipe interior of ventilator with a clean cloth moistened with warm water and mild detergent. Rinse by wiping with a clean cloth moistened with warm water. DO NOT clean by spraying.
4. Dry ventilator thoroughly with a clean non-abrasive cloth.
Reinstall all FILTERS, BAFFLE FILTERS, GREASE CUP(s).
5. Uncover the cooking appliance and reconnect unit to electric power.

Procedure is complete



CAUTION: HOT SURFACE

Exposed surfaces can be hot to the touch and may cause burns. Allow unit to cool before cleaning.



CAUTION: SHOCK HAZARD

DO NOT splash or pour water or grease onto control panel or wiring.

IMPORTANT:

DO NOT wash FILTER PACK. Washing these filters will clog them, and cause installed cooking appliance to be disabled.

IMPORTANT:

DO NOT clean interior of ventilator by spraying.

Spraying can contaminate the cooking appliance, and may cause internal damage to the ventilator blower, operation proofing system and/or fire suppression system.

Clean by wiping only.

REQUIRED MAINTENANCE

IMPORTANT:

Per NFPA 96, a signed and dated VENTILATOR HOOD MAINTENANCE LOG must be maintained on the premises, and be made available for inspection by the authority having jurisdiction upon request.

IMPORTANT:

Should the fire suppression system discharge, all lines and nozzles must be thoroughly cleaned prior to recharging the system.

Be sure to note such cleaning on the hood maintenance log. Residual fire suppression media may compromise the flow and dispersion of fire suppression media in any subsequent activation.

USE AND MAINTENANCE SHALL BE IN ACCORDANCE WITH THE STANDARD FOR VENTILATION CONTROL AND FIRE PROTECTION OF COMMERCIAL COOKING OPERATIONS, N.F.P.A. 96 (current edition).

3-MONTH MAINTENANCE:

Thoroughly clean entire HOOD PLENUM and BLOWER section.

6-MONTH MAINTENANCE:

Inspection and testing of total operation including FIRE DAMPER and all SAFETY INTERLOCKS shall be performed by qualified service personnel.

All FIRE SUPPRESSION SYSTEM actuation components including MANUAL PULL STATION and any REMOTE MANUAL PULL STATION must be inspected for proper operation in accordance with the maintenance schedule published in ANSUL® R-102 SYSTEM DESIGN, INSTALLATION, RECHARGE AND MAINTENANCE MANUAL (418087).

ANNUAL (12-MONTH) MAINTENANCE:

NOZZLES and MANUAL PULL STATION must be cleaned in accordance with ANSUL® R-102 SYSTEM DESIGN, INSTALLATION, RECHARGE AND MAINTENANCE MANUAL (418087).

12-YEAR MAINTENANCE:

The FIRE SUPPRESSION AGENT TANK must be HYDROSTATICALLY TESTED, and the FIRE EXTINGUISHING AGENT must be REPLACED in accordance with the maintenance schedule published in ANSUL® R-102 SYSTEM (STANDARD UL 300 LISTED). This maintenance to be performed by qualified Ansul® service personnel only.

Inspection shall be conducted on a monthly basis in accordance with the manufacturer's Operation Manual. At a minimum, this inspection shall include verification of the following:

WELLS BLOOMFIELD, LLC

VENTILATOR HOOD OWNERS MONTHLY INSPECTION LOG

OPERATION	AGENT / DATE												
Extinguishing system components: In proper place and (visually) in good order													
Manual pull station actuators for fire suppression system are unobstructed													
The maintenance log is in place and up to date													
No obvious physical damage or condition exists that might prevent operation of the fire suppression system													
The nozzle blow-off caps are in place and in good condition													
The hood, duct and protected cooking appliance have not been replaced, modified or relocated													
Clean plenum GREASE BAFFLE and BLOWER (max. interval: 3 months)													
Change PRE-FILTER and FILTER PACK (as required)													

20

IL2144

This MAINTENANCE LOG is to be performed and completed by a trained technician who has completed the instruction necessary to perform the maintenance and recharge service.

WELLS BLOOMFIELD, LLC
VENTILATOR HOOD MAINTENANCE LOG

OPERATION		AGENT / DATE																		
Clean and inspect discharge nozzle in plenum BEFORE filters Max. interval: 6 months																				
Clean and inspect discharge nozzle in plenum AFTER filters Max. interval: 6 months																				
Inspect fire suppression detectors, all releasing devices for actuation, fire suppressant tank liquid level Max interval: 6 months (discharge of fire suppressant not a part of this test)																				
Inspect fire suppression hoses, plumbing and tank for obstructions and any conditions such as, but not limited to, corrosion and pitting. Max. interval: 6 months																				
Inspect and test all filter interlocks Max. interval: 6 months																				
Replace fire damper fusible link rated 212°F Max interval: 12 months	Log TEMP																			
	Log Mfg DATE Stamp																			

21

THIS MAINTENANCE LOG MUST BE KEPT IN A PROTECTIVE COVER PERMANENTLY ATTACHED TO THE APPLIANCE

IL2378a

Log all repairs and recommendations on reverse side. Any repairs, other than replacement of factory authorized parts, to the fire suppression plumbing system must be subject to hydrostatic pressure testing.

Manufacturer's Name: **ANSUL INCORPORATED**
 Address: **One Station Street, Marinette, WI 54143-2542**
 Prepared By: **Safety and Health Department**

Emergency Contact:
 Telephone No.: **(800) 424-8300 or (703) 527-3887**
 Other Information: **(715) 735-7411**
 Date Prepared: **February 1, 1999**

SECTION 1 - IDENTITY

Common Name: (used on label) **ANSUL EX Low pH Liquid Fire Suppressant**
 (Trade Name and Synonyms)
 Chemical Name: **N/A This is a Mixture**
 Formula: **N/A**

CAS No.: **N/A**
 Chemical Family: **Mixture**

SECTION 2 - INGREDIENTS

PART A - HAZARDOUS INGREDIENTS

Principal Hazardous Component(s) (chemical and common name(s)):	Wt. %	CAS No.	ACGIH TLV	Acute Toxicity Data
Name	N/A	N/A	N/A	N/A

PART B - OTHER INGREDIENTS

Other Component(s) (chemical and common name(s)):

Proprietary mixture of organic and inorganic salts	Wt. %	CAS No.	ACGIH TLV	Acute Toxicity Data
Phosphoric Acid	2	7664-38-2	N/E	NDA
EDTA	0.65	64-02-8	N/E	NDA
Yellow-Green Fluorescent Dye	.011	510-47-8	N/E	Oral LD ₅₀ (rat) 6800 mg/kg
Water	Approx. 50.0	7732-18-5	N/E	NDA

SECTION 3 - PHYSICAL AND CHEMICAL CHARACTERISTICS (Fire and Explosion Data)

Boiling Point:	113 °C	Specific Gravity (H ₂ O = 1):	1.33	Vapor Pressure (mm Hg):	Not Determined
Percent Volatile by Volume (%):	Approx. 50	Vapor Density (Air = 1):	1.03	Evaporation Rate (Bunyl Acetate = 1):	Approx. 0.005
Solubility in Water:	100%	Reactivity in Water:	Mild exothermic reaction		
Appearance and Odor:	Fluorescent Yellow colored liquid, mild odor				
Flash Point:	None to boiling	Flammable Limits in Air % by Volume:	N/A	Extinguisher Media:	N/A
Special Fire Fighting Procedure:	NONE - THIS IS AN EXTINGUISHING AGENT			Auto-Ignition Temperature:	N/A
Unusual Fire and Explosion Hazards:	None				

SECTION 4 - PHYSICAL HAZARDS

Stability: Unstable Stable Conditions to Avoid: **N/A**

Incompatibility (Materials to Avoid): **Flammable metals, Cl₂, electrically energized equipment, any material reactive with water.**

Hazardous Decomposition Products: **Not established, acid fumes.**

Hazardous Polymerization: May Occur Will Not Occur Conditions to Avoid: **N/A**

SECTION 5 - HEALTH HAZARDS

ANSULEX Low pH (Continued)

Threshold Limit Value:	None Established			
Route of Entry:	Irritant.			
Eye Contact:	Irritant.			
Skin Contact:	Irritant.			
Inhalation:	Not an expected route of entry. Can be irritating to mucous membranes.			
Ingestion:	Irritating to mucous membranes. Acute Oral LD50 (Sprague-Dawley rats) 825.5 mg/kg.			
Signs and Symptoms:	Acute Overexposure:	Material irritates skin, eyes, and mucous membranes.		
Medical Conditions Generally Aggravated by Exposure:	Chronic Overexposure:	None known.		
Chemical Listed as Carcinogen or Potentially:	National Toxicology Program:	Yes <input type="checkbox"/>	No <input checked="" type="checkbox"/>	IARC Monographs: Yes <input type="checkbox"/> No <input checked="" type="checkbox"/>
				OSHA: Yes <input type="checkbox"/> No <input checked="" type="checkbox"/>

SECTION 6 - EMERGENCY AND FIRST AID PROCEDURES

Eye Contact:	Flush and irrigate with water for 15 minutes while holding eyelids open. If irritation persists, seek Medical attention.
Skin Contact:	Wash thoroughly with soap and water. If irritation persists, seek Medical attention.
Inhalation:	Fresh air if symptoms occur. Seek Medical attention if irritation persists.
Ingestion:	Dilute by drinking large quantities of water.

SECTION 7 - SPECIAL PROTECTION INFORMATION

Respiratory Protection (Specify Type):	N/A	Mechanical (General):	N/A
Ventilation: Local Exhaust:	N/A	Eye Protection:	Chemical goggles recommended during spill/leak procedures.
Protective Gloves:	Rubber gloves for spill/leak.		
Other Protective Clothing or Equipment:	Eye wash and safety showers are good safety practice.		

SECTION 8 - SPECIAL PRECAUTIONS AND SPILL/LEAK PROCEDURES

Precautions to be Taken in Handling and Storage:	Store in original container. Keep tightly closed. Keep separate from acid.
Other Precautions:	See incompatibility information in Section 4.
Steps to be Taken in Case Material is Released or Spilled:	Stop leaks. Contain Spill. Remove as much as possible. Place in closed container for proper disposal. Wash spill area with large amounts of water to remove traces and neutralize.
Waste Disposal Methods:	Dispose of in compliance with local, state, and federal regulations.

HAZARDOUS MATERIAL IDENTIFICATION SYSTEM RATINGS

HAZARD INDEX:	0	HEALTH
4 Severe Hazard	0	FLAMMABILITY
3 Serious Hazard	0	REACTIVITY
2 Moderate Hazard	0	
1 Slight Hazard		
0 Minimal Hazard		

N/A = Not Applicable NDA = No Data Available N/E = None Established

ANSUL and ANSULEX are registered trademarks

Internet Address: <http://www.ansul.com>

ANSUL INCORPORATED, ONE STANTON STREET, MARNETTE, WI 541 43-2542 715-735-7411 Form No. P-90180-8 ©1998 Ansul Incorporated

TROUBLESHOOTING SUGGESTIONS

Problem	Possible Cause	Suggested Remedy
Unit will not operate (no indicators lights lit)	Disconnected from electric power	Reconnect to electric power Reset circuit breaker for unit
Unit will not operate (buzzer sounds)	Fire suppression system not set	Contact an authorized Ansul® distributor for repairs
CHECK FILTER light lit	Filter pack, Pre-filter or baffle filter not in position	Properly install filters
REPLACE FILTER light lit	Filter nearing end of service life	Arrange to replace filters in a timely manner
SERVICE REQUIRED light lit (cooking appliance not operating)	Filter pack plugged	Replace filter pack
	Fire damper in exhaust collar has closed	Contact an authorized Wells service agent for repairs
	One or more vacuum sensing lines or ports plugged, or sensing line dislodged.	Contact an authorized Wells service agent for repairs
	NOTE: If, after 20 seconds, there is insufficient airflow for proper operation, SERVICE REQUIRED light will illuminate and under-hood appliance (s) will be de-energized. Press VENTILATOR POWER SWITCH to O , then back to O to reset system.	

NOTE:

FILTERS are the only user serviceable components in this ventilator hood system. For all problems that cannot be remedied by servicing the filters, contact:

- Ventilator section - authorized Wells service agency
- Fire suppression system - authorized Ansul® distributor

IMPORTANT:

Contact ANSUL® for fire suppression system installation, set-up and service:

Ansul Incorporated 1-800-TO-ANSUL (1-800-862-6785)
 One Station Street
 Marinette, WI 54143-2542 website www.ansul.com

IMPORTANT:

Parts used in the Ansul® fire suppression system are not serviceable by the owner/operator.

Procedures for servicing fire suppression equipment are described in:

ANSUL® Manual 418087 (418087, current edition)

NOTE:

ANSUL® Manual 418087 is intended for use by authorized Ansul® service personnel only.

EXPLODED VIEW & PARTS LIST

Filter Maintenance

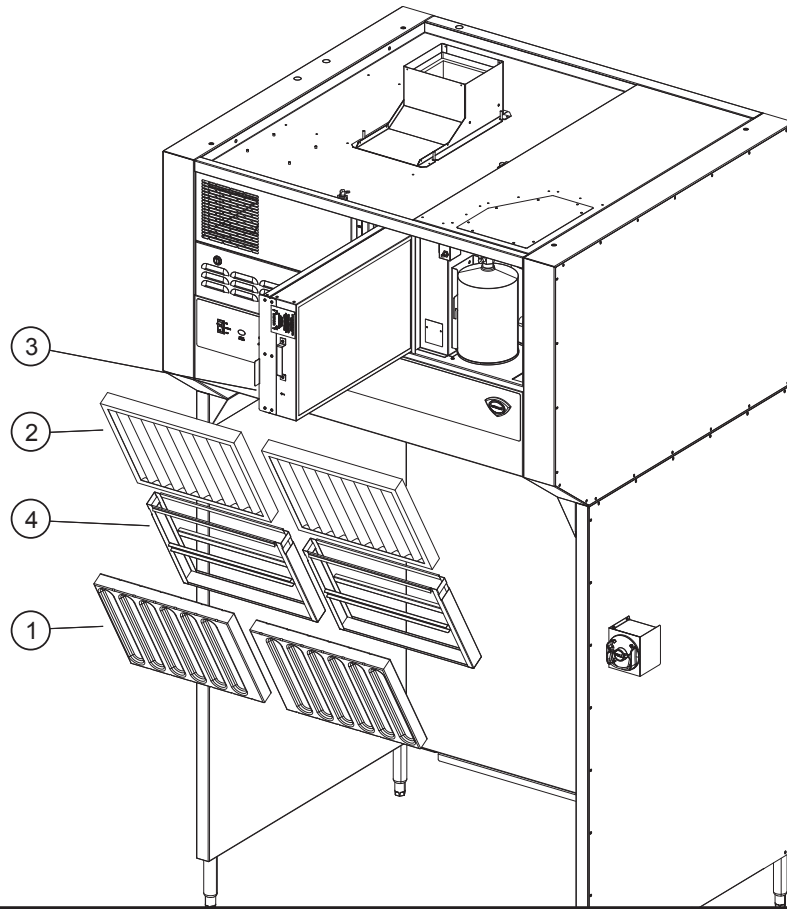

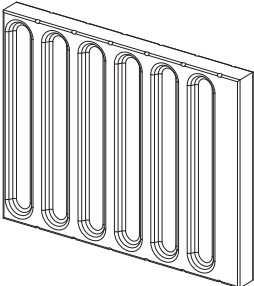
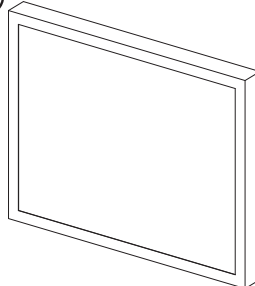
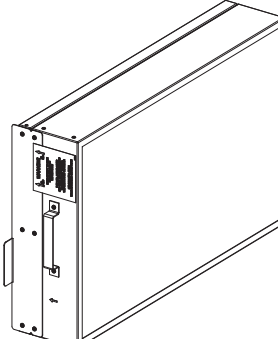
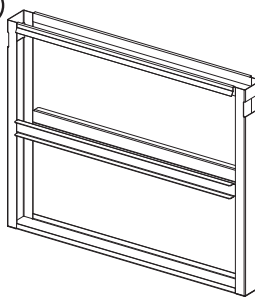
<p>①</p>  <p>Baffle Filter: 16" x 20" Part No: 2I-14670</p>	<p>②</p>  <p>Pre-Filter Hood Part No: 2I-1628</p>
<p>③</p>  <p>Filter HEPA/Carbon Pac Part No: N1-WL0171</p>	<p>④</p>  <p>Pre-Filter Cage Part No: M3-WL0230</p>

Model: WVU48 Filter Assy

S23 Rev. A, 8/27/2012

EXPLODED VIEW & PARTS LIST

Filter Maintenance

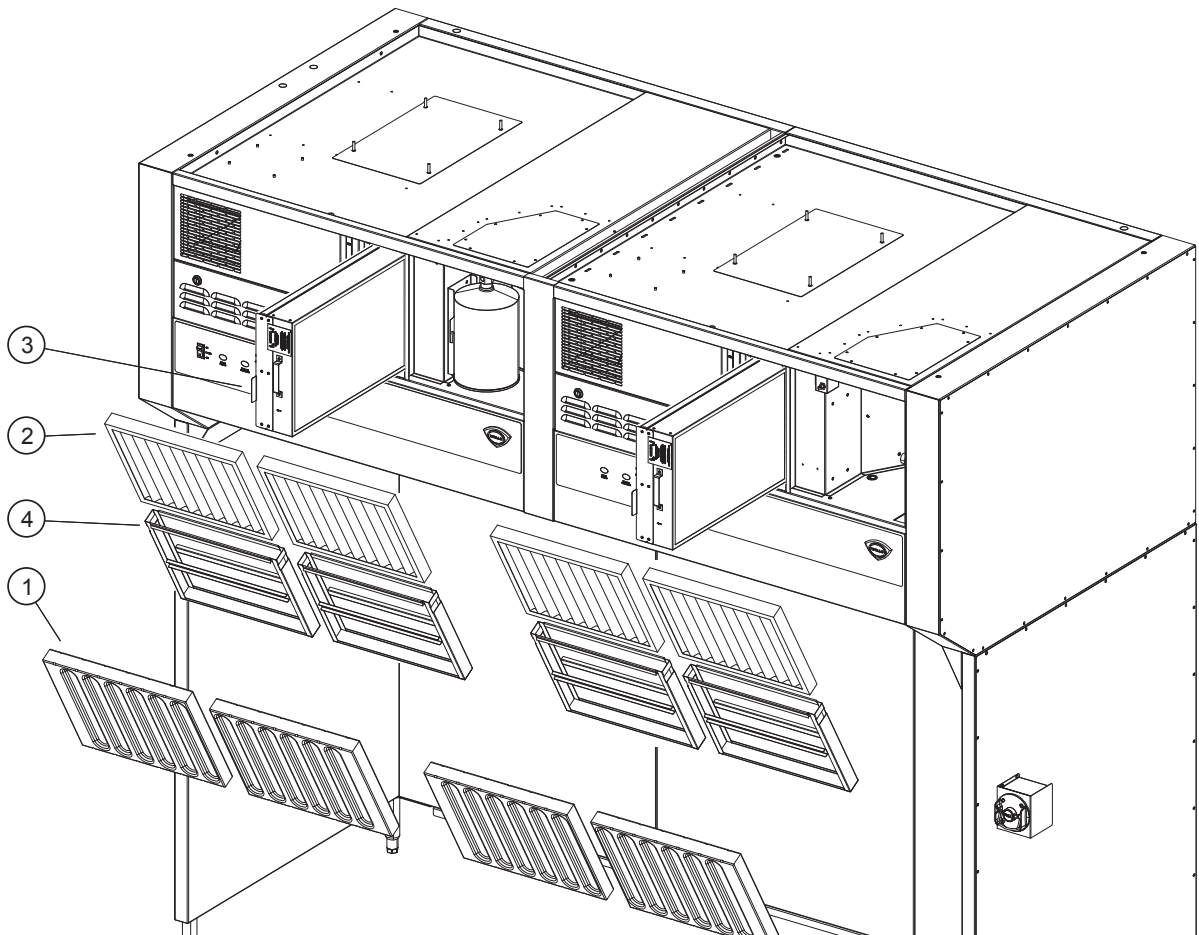

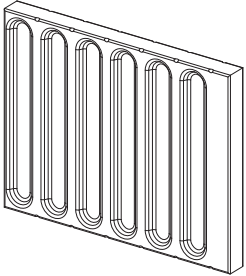
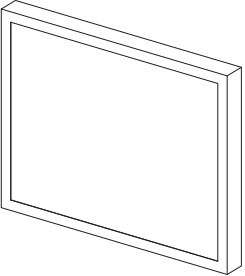
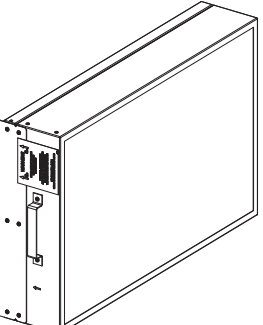
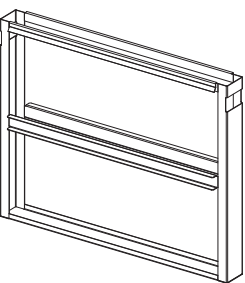
<p>①</p>  <p>Baffle Filter: 16" x 20" Part No: 2I-14670</p>	<p>②</p>  <p>Pre-Filter Hood Part No: 2I-16218</p>
<p>③</p>  <p>Filter HEPA/Carbon Pac Part No: N1-WL0171</p>	<p>④</p>  <p>Pre-Filter Cage Part No: M3-WL0230</p>

Model: WVU96 Filter Assy

S2176 Rev. A, 8/27/2012

EXPLODED VIEW

Universal Hood Internal Control

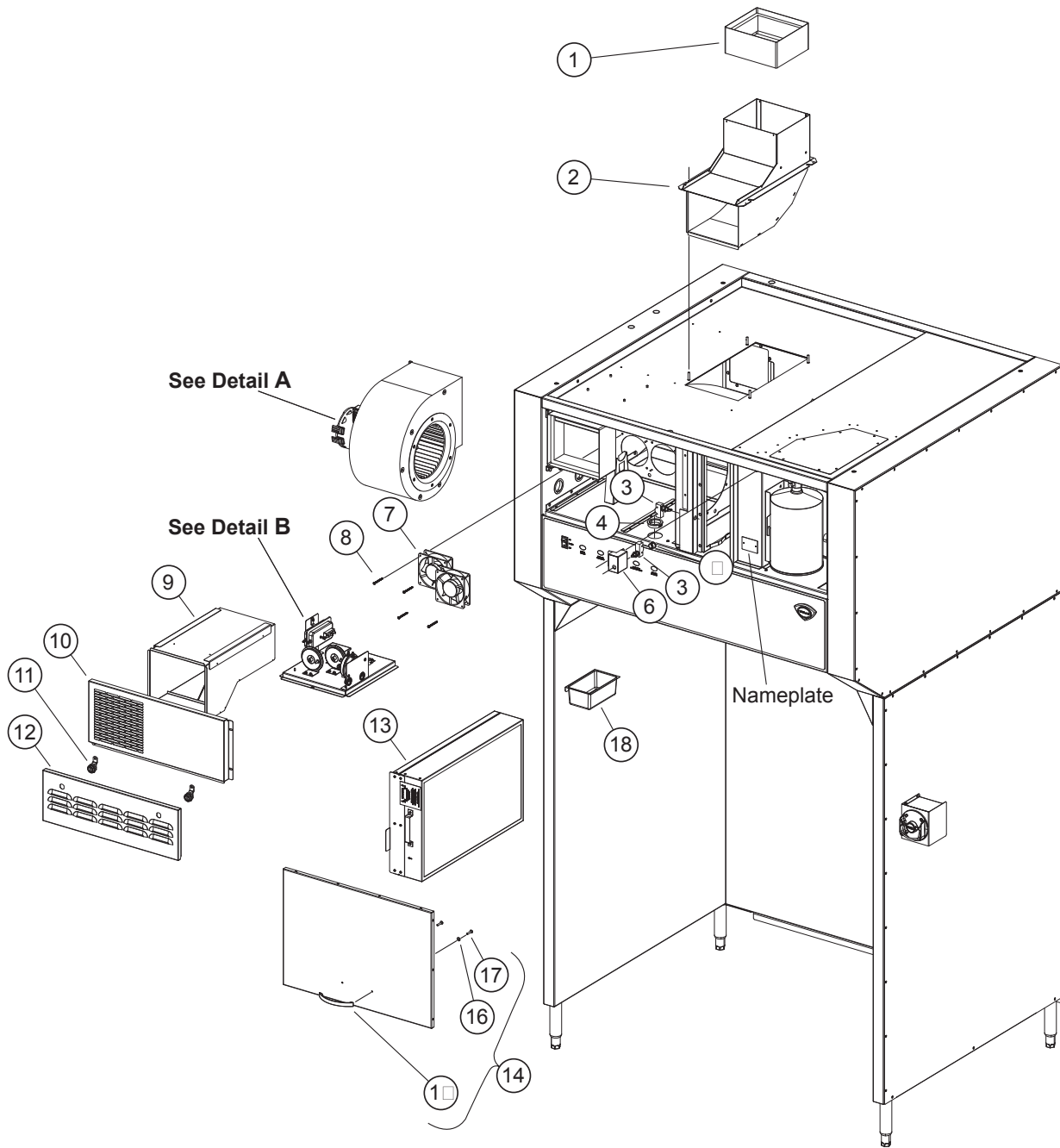

Model: WVU48 Universal Hood Internal Control



S□2□4 Rev. - 1/16/2012

M522 p/n 2M-Z16247 OpM WVU- Universal Hood

PARTS LIST

Universal Hood Internal Control

Internal Control Assy				
Fig No.	Part No	WVU48	WVU96	Description
1	2V-307913	1	2	DAMPER FIRE 8X9 WVU
2	N1-WL0244	1	2	TOP DISCHARGE SCOOP ASSY.
3	2E-300407	6	12	SWITCH MANUAL ADVANCE ROT
4	2K-Y8571	3	7	BUSHING SNAP 2 1/8
5	2K-Y1139	1	2	BUSHING HEYCO SB500-6
6	N1-Z14484	1	2	MOUNTING BRACKET, DOOR
7	2U-200577	2	4	MOTOR, FAN 240V, HI-OUTPU
8	2C-45201	4	8	SCREW 8-32X2 PH PAN HD MS
9	N1-WL0172	1	2	DUCTWORK ASSEMBLY
10	N1-Z14097	1	2	FRONT DISCHARGE VENTPANEL
11	2R-Z14532	2	4	CAM LATCH, SLOTTED
12	N1-Z14087	1	2	ACCESS DOOR, ELECT
13	N1-WL0171	1	2	FILTER HEPA/CARBON PACK
14	N1-WL0170	1	2	DOOR ASSY,FRONT ANSUL
15	2R-Z14429	1	2	HANDLE, 5"
16	2C-1810	2	4	WASHER 3/16 BURR STL NP
17	Included with #15	2		
18	2D-Z14672	1	2	GREASE CUP

EXPLODED VIEW & PARTS LIST

Universal Hood Internal Control (Detail A)

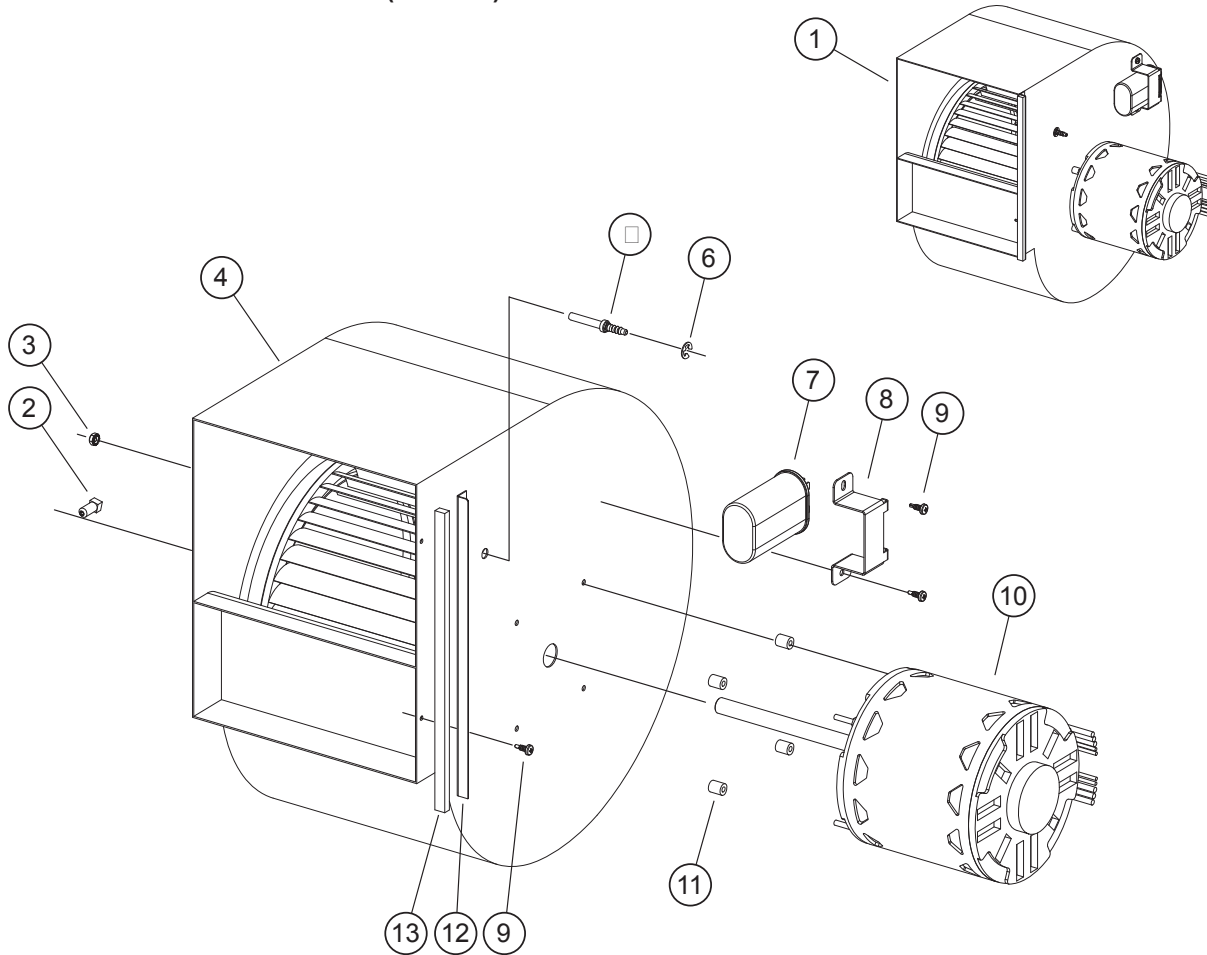

Detail A
Blower □ Motor Assy

S□2□□ Rev. - 1/16/2012

DETAIL A, Blower & Motor Assy				
Fig No.	Part No	WVU48	WVU96	Description
1	NI-WL0247	1	2	Blower & Motor Assy
2	Included w/ no 4	1	2	
3	2C-31053	4	8	NUT #8-32 KEPS NICKEL
	2C-1810	4	8	3/16 WASHER BURR STL NP
4	2U-Z14912	1	2	BLOWER & WHEEL ASSY
5	2A-Z15331	1	2	PRESSURE TAP TUBE FITTING
6	2C-Z15332	1	2	E-CLIP RETAINING RING 1/4"
7	2E-Z14913	1	2	RUN CAPACITOR, 10MFD, 370V
8	N1-Z15392	1	2	BRACKET, RUN CAPACITOR
9	2C-301522	4	8	SCREW 8X12 RPH PAN SELF DRILLING
10	N1-Z14911	1	2	BLOWER MOTOR MODIFIED
11	2C-Z15394	4	4	SPACER STAND-OFF, 7/16"
12	N1-Z15316	1	2	SIDE FLANGE, BLOWER HOUSING
13	N1-Z15317-1	1	2	GASKET TAPE 10.25 LG, BLOWER SIDE FLANGE

M522 p/n 2M-Z16247 OpM WVU- Universal Hood

EXPLODED VIEW & PARTS LIST

Universal Hood Internal Control (Detail b)

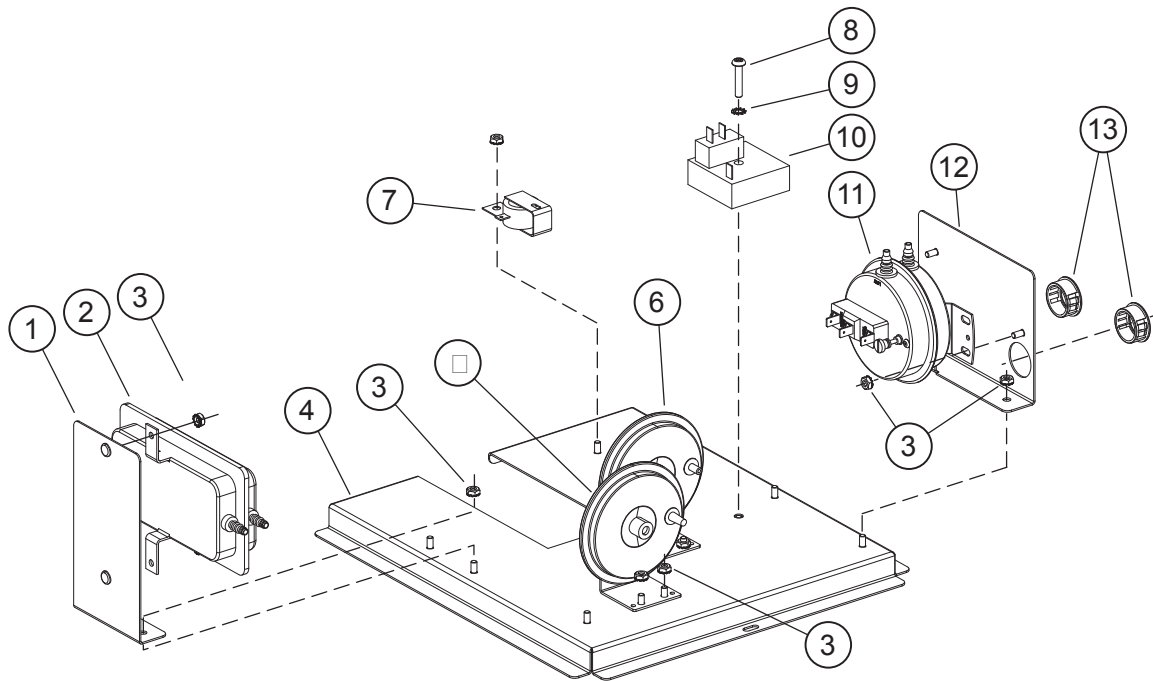

Detail B
Internal Control Panel Assy

S□2□□6 Rev. - 1/16/2012

DETAIL B, Internal Control Panel Assy

Fig No.	Part No	WVU48	WVU96	Description
1	N1-Z15362	1	2	BRACKET, PRESSURE SWITCH (AIR CURTAIN)
2	2E-Z14673	1	2	PRESSURE SWITCH, (AIR CURTAIN)
3	2C-Z7165	13	26	NUT, 8-32 UNC KEPS
4	N1-Z14138	1	2	MOUNTING PLATE, INTERNAL CONTROLS
5	2E-302591	1	1	VACUUM SWITCH, PREFILTER
6	2E-Z15352	1	2	VACUUM SWITCH, HEPA FILTER
7	2J-44834		1	BUZZER 220V ROHS
8	2C-1516		1	10-24 X 1 PHILLIPS ROUND HEAD MACHINE SCREW
9	2C-1827		1	#10 EXTERNAL TOOTH LOCK WASHER
10	2P-302939		1	TIMER CUBE, RELAY
11	2E-Z15365	1	2	PRESSURE SWITCH, (SHUTDOWN)
12	N1-Z14886	1	2	BRACKET, PRESSURE SWITCH (SHUTDOWN)
13	2K-Y5093	2	4	BUSHING, SB-1000-12

EXPLODED VIEW

Universal Hood Electrical Components

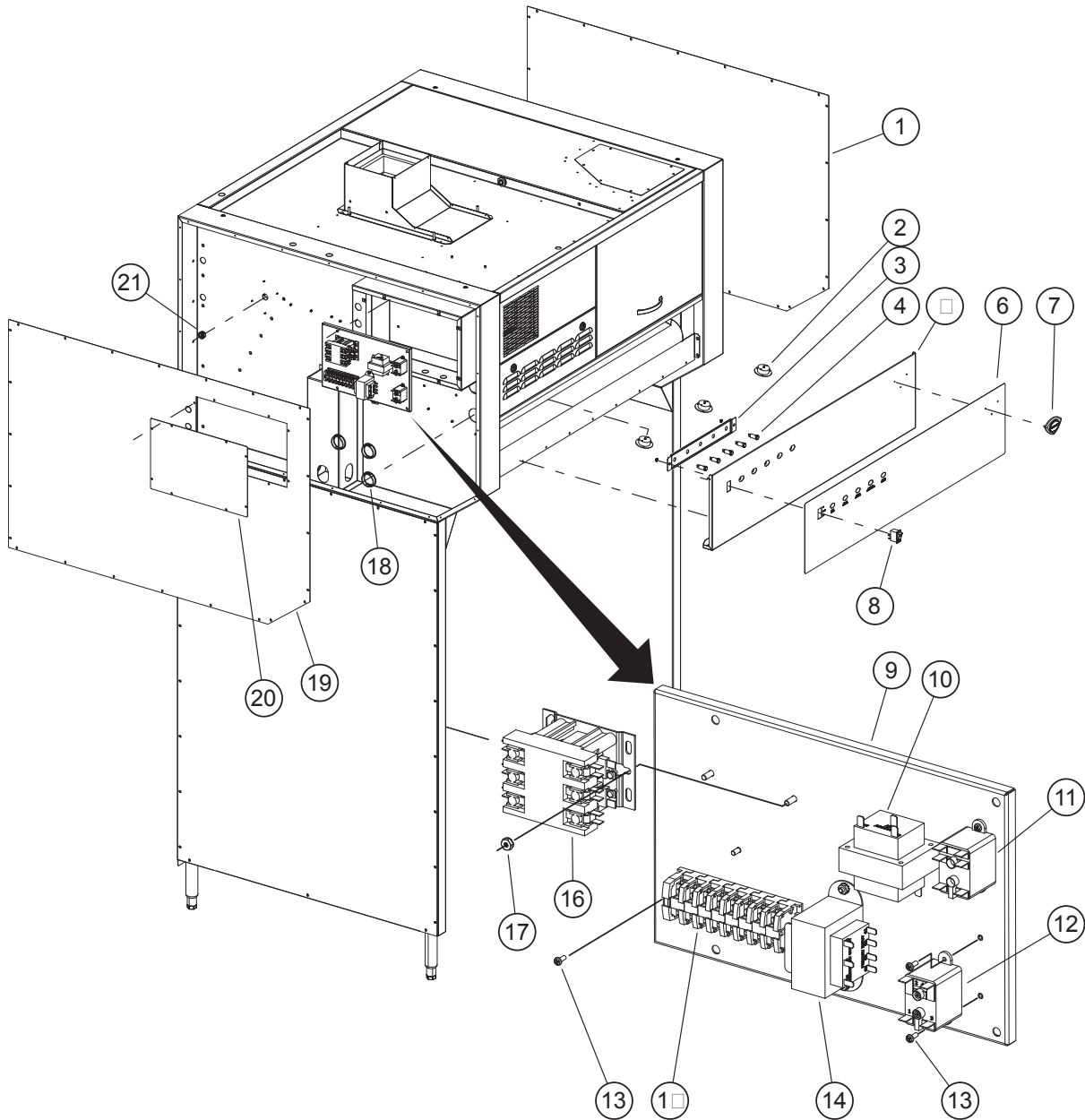

Electrical Components



S□2□□7 Rev. - 1/16/2012

M522 p/n 2M-Z16247 OpM WVU- Universal Hood

PARTS LIST

Universal Hood Electrical Components

Control Panel				
Fig No.	Part No	WVU48	WVU96	Description
1	N1-Z14142		1	COVER, HOOD SIDE RIGHT
2	N1-WL0245	3	6	LED FLOODLIGHT, 45W CW w/TERM
3	N1-Z15418	1	2	MOUNTING PLATE, CTRL LIGHT
4	N1-WL0281	5	10	LIGHT SIGNAL, CLEAR LED w/TERM
5	N1-WL0250	1		CONTROL PANEL, FRONT ASSY
5	N1-WL0278		1	CONTROL PANEL, FRONT ASSY
6	2M-Z14069		1	GRAPHIC PANEL, NO SWITCH
6	2M-Z14510	1		GRAPHIC PANEL W/ SWITCH
7	2M-306719	1	2	LOGO WELLS DIECAST SHIELD
8	2E-305295		1	SWITCH ROCKER 250V 10A GR
9	N1-Z15435		1	ELEC. AUTOMAN BKT. MODIFY
10	2E-Z15018	1	2	TRANSFORMER, 208/240 12V
11	2E-44514		1	RELAY 208-240V COIL
12	2E-Z15353		1	RELAY, 120V COIL, SPNO
13	2C-1488		6	SCREW 6-32X3/8 RHP STL NP
14	2E-Z15335		1	TRANSFORMER, 208/240
15	WS-WL0282		1	TERMINAL BLOCK ASSY
16	2E-Z14960		1	CONTACTOR, 40A
17	2C-40680		2	NUT 10-32 HEX KEPS MS SS
18	2K-Y8571	3	7	BUSHING SNAP 2 1/8
19	N1-Z14141		1	COVER, HOOD SIDE LEFT
20	N1-Z15344		1	COVER, SIDE ELECTRIC BOX
21	2K-8043		2	BUSHING HEYCO SB-875-10

EXPLODED VIEW & PARTS LIST

Universal Hood Suppression System

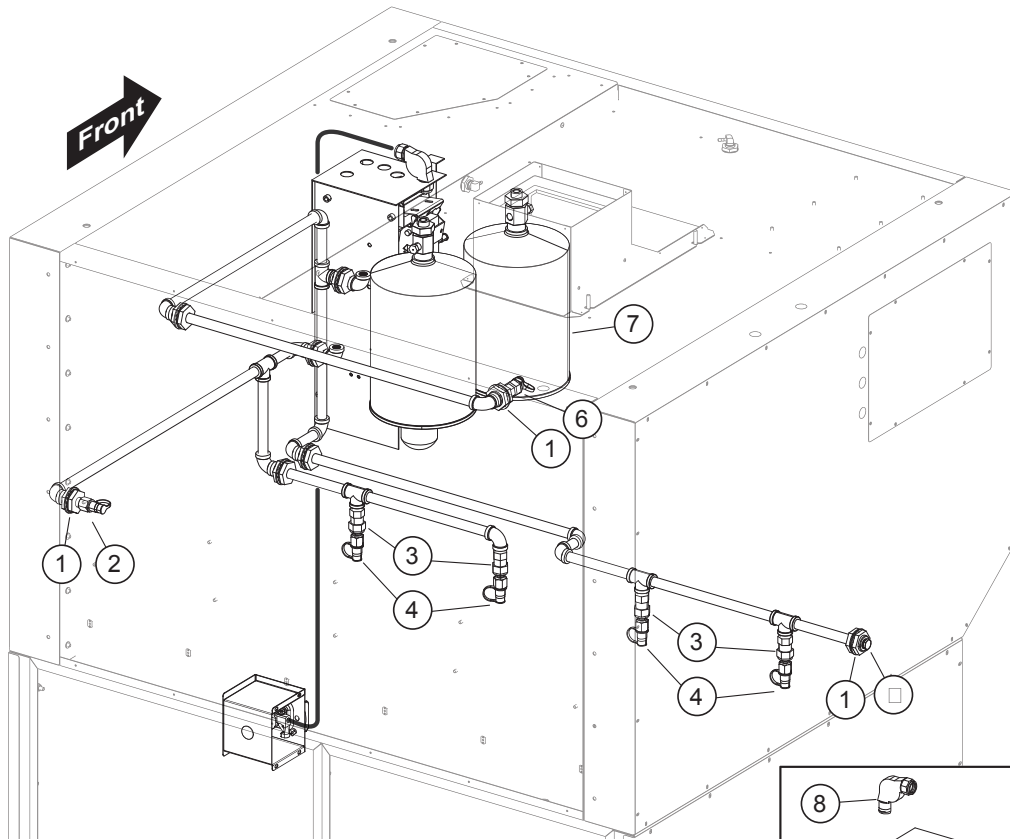

Suppression System

Fig. No	Part No	WVU48	WVU96	Description
1	2K-47269	8	16	ADAPTER 3/8IN QUICK CON A
2	2O-47267	1	2	NOZZLE ANSUL 1N
3	2O-307481	5	10	ADAPTER SWIVEL ANSUL
4	2O-Z14574	4	8	NOZZLE, #245
5	2C-Z15115	1	2	HEX HEAD PIPE PLUG 3/8NPT
6	2O-302931	1	2	NOZZLE 1 W
7	2O-304433	2	4	TANK SS ANSULEX 1.5 GALLO
8	2O-47272		1	PULLEY ELBOW
9	N1-Z15435	1	2	ELEC. AUTOMAN BKT MODIFY
10	2O-Z14918	1	2	ANSUL CARTRIDGE LT-30-R
11	2O-308131		1	REMOTE PULL STATION RED

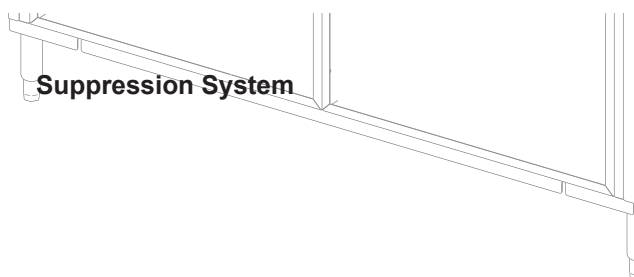
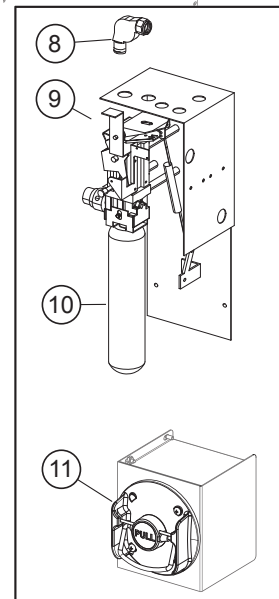

S□2□8 Rev. - 1/16/2012

EXPLODED VIEW & PARTS LIST

Universal Hood Detection System

Adapter 1/2" Quic-Seal
Part No: 2T-1320

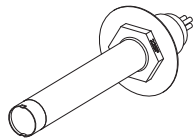
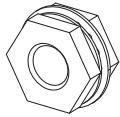

Thermal Detector-22°F
Part No: 2T-1320

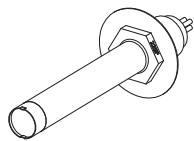

Thermal Detector-27°F
Part No: 2T-16137

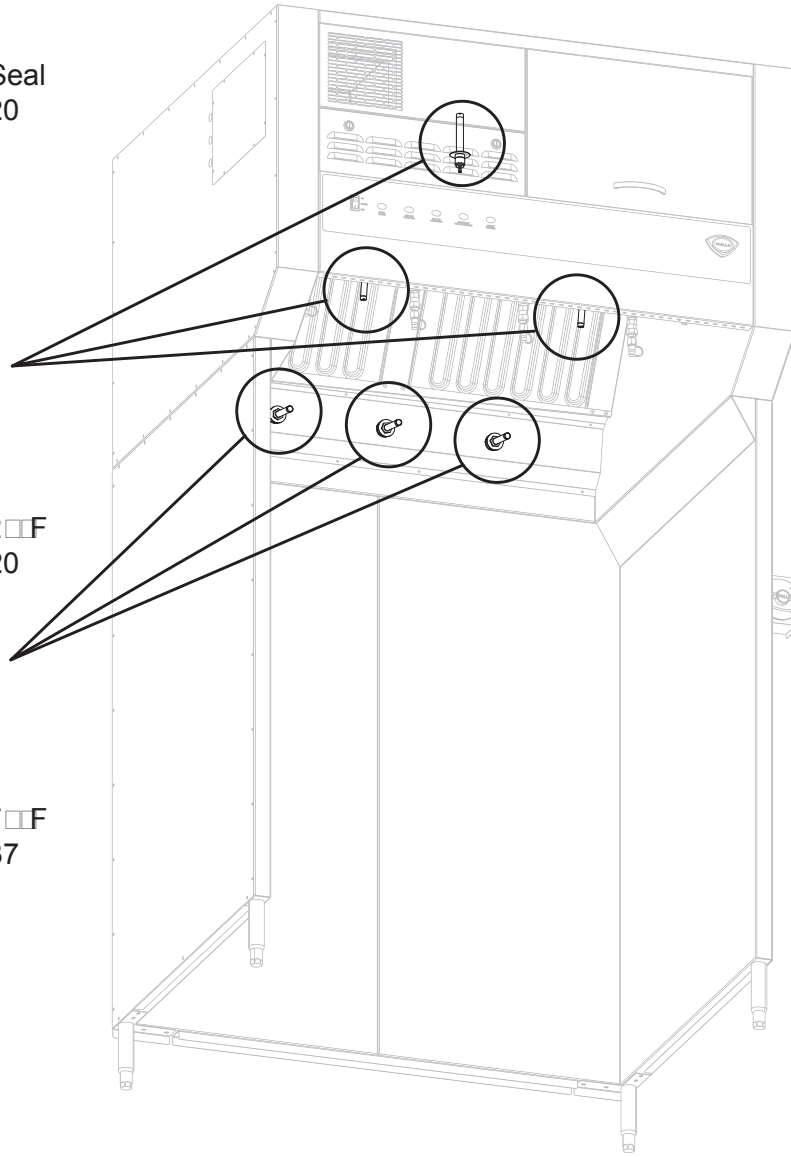

Detection System

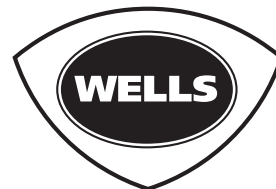

S209 Rev. A 7/2012

M522 p/n 2M-Z16247 OpM WVU- Universal Hood

EXPLODED VIEW & PARTS LIST

Universal Hood Base Assy

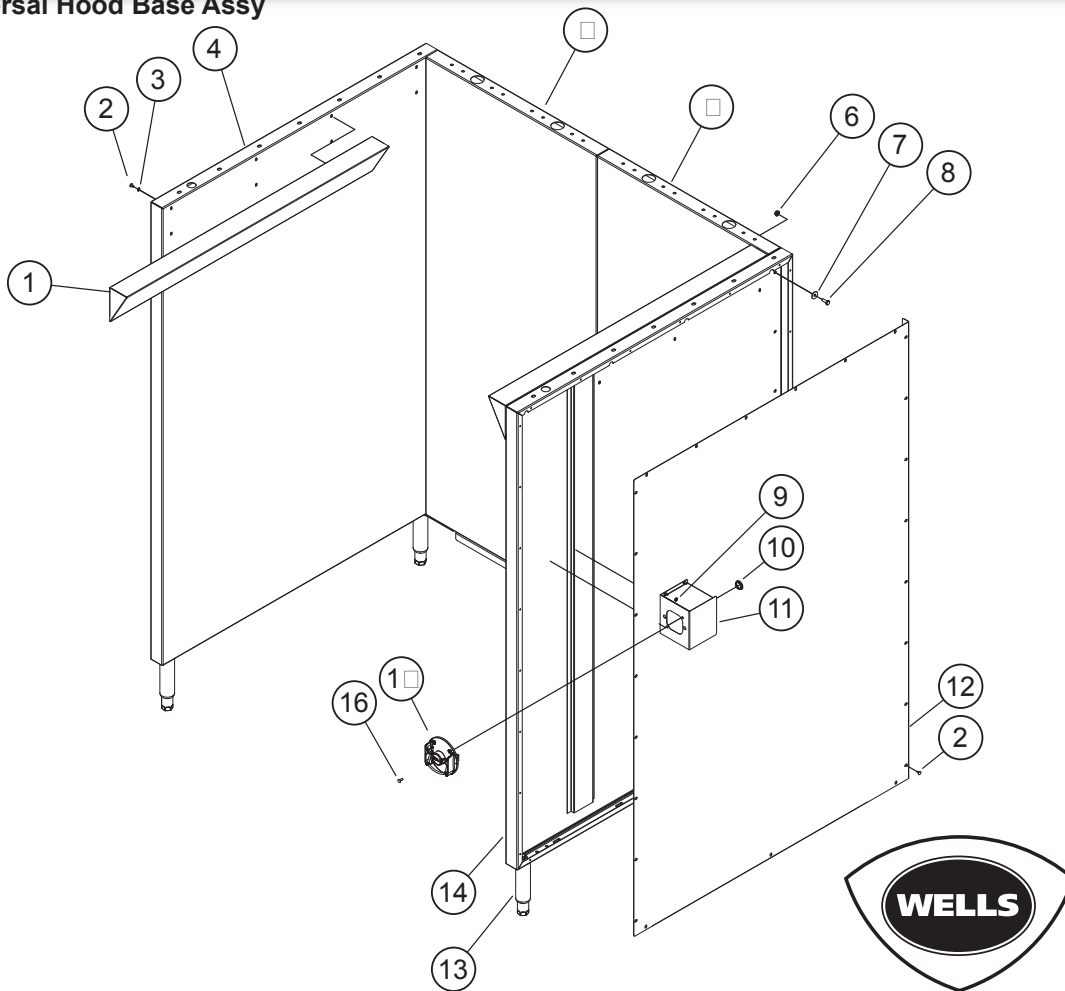

Model: WVU48 Base Assy

S□2□61 Rev. - 1/16/2012

Base Assembly				
Fig No.	Part No	WVU48	WVU96	Description
1	N1-Z15193	2		BASE DEFLECTOR
2	2C-35487	66		SCREW 8-32X5/16 PH TR HD
3	2C-1825	16		WASHER #8 EXT STL NP
4	N1-WL0176	1		BASE,SUPPORT ASSY LFT
5	N1-Z14147	2		BASE,BACK SUPPORT
	N1-Z14149		3	BASE,BACK SUPPORT 8FT
6	2C-6517	70	85	NUT 1/4-20 HEX STL NP
7	2C-A27469	70	85	WASHER,FLAT 1/4IN 7/8OD 1
8	2C-Z5555	70	85	BOLT 1/4-20 X .75 HEX SS
9	2C-31053		4	NUT 8-32 KEPS MS NICKEL
10	2P-70903-05		1	PLG BTN PLTD MTL 7/8
11	N1-WL0126		1	BOX, MANUAL PULL ASSEMBLY
	N1-WL0180		1	COVER,BASE SIDE RT ASSY
	N1-Z14152		1	COVER, BASE SIDE LEFT
13	2A-307628		4	LEG 6 ADJ 1/2-13 SS
14	N1-WL0177		1	BASE,SUPPORT ASSY RT
15	2O-308131		1	REMOTE PULL STATION RED
16	2C-31730		2	SCREW 8-32X1/2 PH TR HD M

M522 p/n 2M-Z16247 OpM WVU- Universal Hood

PARTS & SERVICE

DESCRIPTION

PART NO.

IMPORTANT: Use only factory authorized service parts and replacement filters.

For factory authorized service, or to order factory authorized replacement parts, contact your Wells authorized service agency, or call:

Wells Bloomfield, LLC
10 Sunnen Dr.
St. Louis MO 63143 USA

Service Dept.
phone: (314) 678-6314
fax: (314) 781-2714

Service Parts Department can supply you with the name and telephone number of the WELLS AUTHORIZED SERVICE AGENCY nearest you.

CUSTOMER SERVICE DATA

please have this information available if calling for service

RESTAURANT _____ LOCATION _____

INSTALLATION DATE _____ TECHNICIAN _____

SERVICE COMPANY _____

ADDRESS _____ STATE _____ ZIP _____

TELEPHONE NUMBER (____)____-_____

EQUIPMENT MODEL NO. _____ EQUIPMENT SERIAL NO. _____

VOLTAGE: (check one) 208 240



Wells Bloomfield proudly supports CFESA
Commercial Food Equipment Service Association

SERVICE TRAINING - QUALITY SERVICE



CUSTOMER SATISFACTION



WELLS BLOOMFIELD, LLC
10 Sunnen Dr., St. Louis, MO 63143
telephone: 314-678-6314
fax: 314-781-2714

□□□□ells□loo□ield□□□