



TOWN



TOWN FOOD SERVICE EQUIPMENT CO., INC.
72 BEADEL STREET, BROOKLYN, NY 11222
Ph. (718) 388-5650 Fax (718) 388-5860
(800) 221-5032 www.townfood.com

SR-24 -G- STOCK POT STOVE



GENERAL

The SR-24-G Grate Top Stock Pot range offers very high BTU input (137 MBTU) with the supplied (standard) 3 ring burner, complete with Town's exclusive clog resistant pilot. An aluminum heat shield between the combustion chamber and outer body insures cool operation of the unit. Delta T rated Solid brass valves with solid metal handles are standard. The Outer body and legs are Stainless Steel. A rugged interior chassis, formed from heavy duty steel angle iron is standard. Rear Gas connection, pressure regulator and galvanized drip pan are standard.

MODEL

SR-24-G is available for use with either Natural or Propane fuel. Specify gas type when ordering. Designed for stock preparation. It accommodates standard 55 qt. commercial stock pots.



STANDARD FEATURES

- Design certified by ETL for conformance to ANSI Z83.11-2007
- Design certified by NSF and /or ETL for conformance to ANSI/NSF-4
- Heavy Duty cast iron grate top
- Interior heat shield
- Solid brass valves - Delta T rated
- All stainless Steel exterior construction
- Rigid, durable angle iron chassis
- High output burner is standard
- Clog resistant standing pilot/ with control valve
- Stainless steel legs with "bullet" adjusters
- 3/4" NPT rear gas connection with regulator
- MEA and MA Plumbing Board Approved

OPTIONS

- Jet tip and shield tip options are available
- Custom leg heights
- Double insulated chassis
- Wok adaptor
- Castors
- Stainless Steel Drip Pan
- Pilot gas safety system

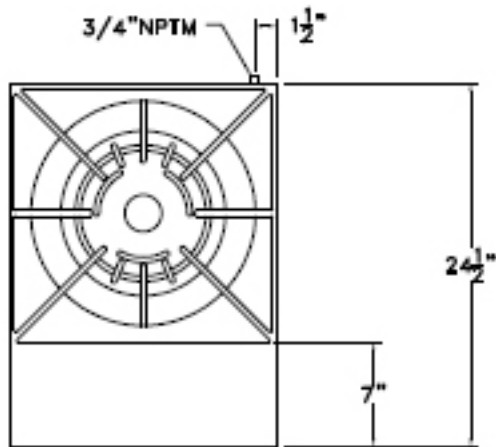

SR-24-G

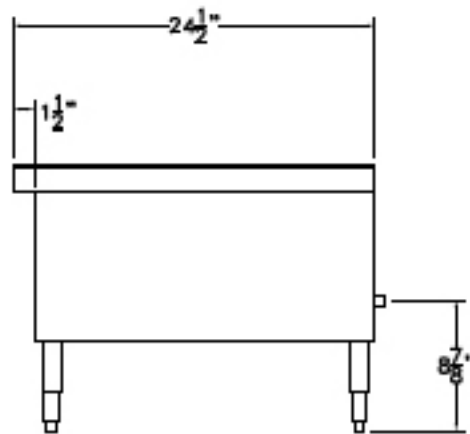
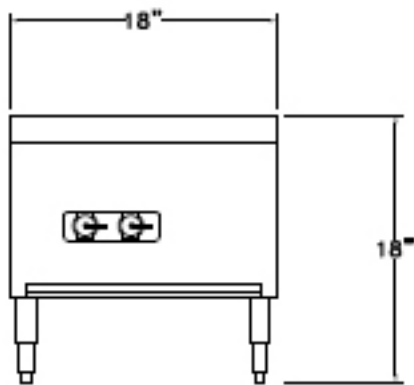

IMPORTANT

Commercial gas range(s) must be installed in accordance with state and local codes, or in the absence of local code with the NATIONAL FUEL GAS CODE- ANSI Z223.1. COMPLIANCE WITH ALL CODES IS THE RESPONSIBILITY OF THE OWNER AND THE INSTALLER.

COMMERCIAL GAS UNITS NEED ADEQUATE VENTILATION SYSTEMS. REFER TO NATIONAL FIRE PROTECTION ASSOCIATION STANDARD NO 96- "VAPOR REMOVAL FROM COOKING EQUIPMENT"

CERTIFIED BY ETL TO CONFORM TO ANSI Z83.11- "GAS FOODSERVICE EQUIPMENT."
NOT INTENDED FOR HOUSEHOLD USE. FOR USE BY PROFESSIONALLY TRAINED PERSONNEL ONLY.

CERTIFIED BY ETL/NSF TO NSF4/ANSI-4-COMMERCIAL COOKING, RETHERMALIZATION AND HOT FOOD EQUIPMENT- "SANITATION."

MINIMUM CLEARANCES- COMBUSTIBLE AND NON COMBUSTIBLE:
Back Wall- 6" Left and Right Sides- 6" For use on non combustibile floors only.

Town reserves the right to change design without notification.