



Take your bake anywhere! New Optional Ventless Internal Catalyst Design.

**CONVECTION OVEN
SL - SERIES
ELECTRIC, SINGLE DECK**



SLES/10SC shown with optional casters

- SLES/10SC
- SLES/10TC
- SLEB/10SC
- SLEB/10TC

Standard Features

- Energy Star Compliant (Standard depth)
- 11kW high efficiency heating elements
- Available standard and bakery depths.
- Single deck convection oven is 55" in height(with optional casters)
- Patented "plug-in, plug-out" control panel - easy to service
- Slide out control panel for full view servicing
- Stainless Steel front, top and sides
- Dependent glass doors (Full 180° opening)
- Energy saving high efficiency glass windows
- Heat keeping dual door seal system
- Coved, fastener-free, porcelain interior
- Stay cool heavy duty door handle
- Two speed, 1/2 hp, fan motor
- 11-position rack guides and 5 plated oven racks
- Solid state temperature controls
- Forced cool down fan mode
- Oven "heat" light cycles with burners
- Interior oven lights
- (1) year limited parts and labor warranty (reference <http://www.southbendnc.com/service.html> for limited warranty details)

Available Controls

SC-Standard Controls

140°F to 500°F solid state thermostat and 60 minute mechanical cook timer.

TC-Touchscreen Controls

150°F to 550°F temperature controller with 140°F to 200°F "Hold" thermostat. Digital display shows time and temperature. A fan cycle timer pulses the fan. Recipes can be created and used in oven group 'Rack' mode to cook multiple items at once on different timers.

OPTIONS & ACCESSORIES AT ADDITIONAL COST

- | | | |
|--|---|--|
| <input type="checkbox"/> Ventless Design *(UL certified) | <input type="checkbox"/> Stainless steel exterior bottom | <input type="checkbox"/> Down draft diverter for direct flue |
| <input type="checkbox"/> List the voltage, frequency, and amps (see utility information).
____VAC, ____Phase, ____Hz. | <input type="checkbox"/> Stainless steel legs with rack pan guide kit | <input type="checkbox"/> Export crating |
| <input type="checkbox"/> Stainless steel rear jacket | <input type="checkbox"/> Casters 4" or 6" | <input type="checkbox"/> Marine edge top |
| | <input type="checkbox"/> Stainless steel dirt tray | <input type="checkbox"/> Stainless steel doors |
| | <input type="checkbox"/> Swivel Caster - front with locks | |

STANDARD CONSTRUCTION SPECIFICATIONS

Exterior Finish: Stainless steel front, top and sides.

Doors: Dependent doors with windows. Low emission glass, stainless steel construction, heavy-duty welded steel frame and 5/8" diameter full-length hinge pin.

Oven Interior: Porcelain enamel finish, coved, fastener free.

Rack and Rack Guides: Heavy-duty removable wire rack guides spaced on 1-5/8" centers offer 11 different rack positions. 5 wire racks provided with each oven.

Blower Fan and Motor: 1/2hp, 2-speed motor, 1710/1120 r.p.m

Oven Heating: Oven heating is regulated by an adjustable solid state thermostat control. Blower fan circulates air within the cavity "scrubbing" heat to the oven interior for even heat distribution within the cavity. Manual reset high limit temperature control protects the oven from overheat condition.

Control Panel: Located on front, at right side of oven, away from heat zone. Slide out panel extends over 17" for easy servicing.

Interior Lights: Two 40 watt high temperature recessed lamps located within the oven cavity

Legs: 26" Stainless steel, triangular legs standard.

Electrical System: Terminal connections are located below oven section and are accessible from the front of the oven. These sheath type electrical heating elements located at the rear of the oven function as a single heating unit with a combined rating of 11 kW. Available voltages include 208, 240, 380, and 480 VAC single or three phase, 50/60 Hz. Ovens equipped with 480VAC single or three phase heating elements use 240V controls and motors and do not require separate electrical lead wires.



Approval Notes: _____

SLE10

Dimensions shown in inches and (millimeters)

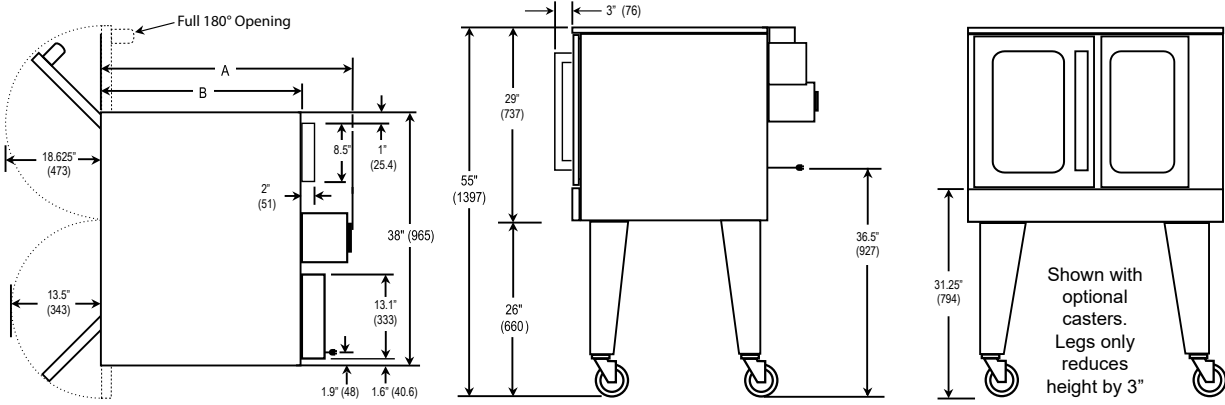

DIMENSIONS

MODEL	DEPTH		OVEN INTERIOR			RACK CLEARANCE		SHIPPING CRATE				
	A	B	WIDTH	DEPTH	HEIGHT	WIDTH	DEPTH	WIDTH	DEPTH	HEIGHT	VOLUME	WEIGHT
SLES/10	37.25" (946)	30.25" (768)	29" (737)	21.50" (546)	20" (508)	28.25" (718)	21" (533)	57.50" (1461)	45.50" (1156)	45" (1143)	68.1 cu. ft. (1.93 cu. m.)	620 lbs (281.2 kg.)
SLEB/10	43.50" (1105)	36.50" (927)	29" (737)	29" (737)	20" (508)	28.25" (718)	27.25" (692)	57.50" (1461)	45.5" (1156)	45" (1143)	68.1 cu. ft. (1.93 cu. m.)	690 lbs (313.0 kg.)z

Note: When shipped on legs, crated height is 69" (1753 mm)

Dimensions shown in inches and (millimeters)

UTILITY INFORMATION

Standard: 1/2 horsepower, 2 speed motor, 1710/1120 r. p. m.

EACH OVEN	ELECTRICAL DATA		AMPS PER LINE			
	VOLTAGE	1 PHASE	3 PHASE			
			X	Y	Z	NEUT.
12 kW Heating Elements and Controls (11kW for Heating Elements, 1kW for Controls)	208 VAC, 60Hz	58	34	34	31	0
	220/240 VAC, 50Hz	46	28	28	24	0
	240 VAC, 60Hz	50	30	30	26	0
	380/220 VAC, 50Hz	32	17	17	21	4
	415/240 VAC, 50Hz	50	15	15	19	4
	480 VAC, 60Hz	25	14	14	13	0

* Electric units available for single or three phase operation and must be specified upon ordering.

MISCELLANEOUS

- Clearances from combustibles: Top, bottom, right, left side -0".
- Recommended - install under vented hood.
- Check local codes for fire and sanitary regulations.

NOTICE:

Southbend has a policy of continuous product research and improvement. We reserve the right to change specifications and product design without notice. Such revisions do not entitle the buyer to corresponding changes, improvements, additions or replacements for previously purchased equipment.

**INTENDED FOR COMMERCIAL USE ONLY.
NOT FOR HOUSEHOLD USE.**

