



Profit from the Eagle Advantage®

# Specification Sheet

## Short Form Specifications

Eagle 1800 Series Cocktail Unit, model \_\_\_\_\_. Top, front, backsplash and ice bin to be heavy gauge type 304 stainless steel. Ice bin to be deep-drawn seamless design, fully insulated, with 1½" drain and plastic bottle holders. 1½" O.D. galvanized tubular legs with welded crossbracing and adjustable bullet feet.

Eagle 1800 Series Cocktail Unit with Sealed-In Cold Plate, model \_\_\_\_\_. Top, front, backsplash and ice bin to be heavy gauge type 304 stainless steel. Ice bin to be deep-drawn seamless design, fully insulated, with sealed-in 7-circuit cold plate and 1½" drain. 1½" O.D. galvanized tubular legs with welded crossbracing and adjustable bullet feet.



#B2CT-18 cocktail unit

## Options / Accessories

- Speed rail
- Stainless steel leg kits (see below)

### Optional Stainless Steel Leg Kits for Cocktail Units

add suffix #	description
-SL	stainless steel leg assemblies
-SLF	stainless steel leg assemblies & stainless steel feet
-SLG	stainless steel leg assemblies & stainless steel gussets
-SLGF	stainless steel leg assemblies, stainless steel feet & gussets

**EAGLE GROUP**  
100 Industrial Boulevard, Clayton, DE 19938-8903 USA  
Phone: 302-653-3000 • Fax: 302-653-2065  
www.eaglegrp.com

**Foodservice Division: Phone 800-441-8440**  
**MHC/Retail Display Divisions: Phone 800-637-5100**

For custom configuration or fabrication needs, contact our **SpecFAB® Division**.  
Phone: 302-653-3000 • Fax: 302-653-3091 • e-mail: specfab@eaglegrp.com

Item No.: \_\_\_\_\_  
 Project No.: \_\_\_\_\_  
 S.I.S. No.: \_\_\_\_\_

## 1800 Series Cocktail Units

### MODELS:

- |                                    |  |  |
|------------------------------------|--|--|
| <input type="checkbox"/> B2CT-18   | <input type="checkbox"/> B2CT-12D-18   | <input type="checkbox"/> B2CT-16D-18   |
| <input type="checkbox"/> B3CT-18   | <input type="checkbox"/> B3CT-12D-18   | <input type="checkbox"/> B3CT-16D-18   |
| <input type="checkbox"/> B2CT-18-7 | <input type="checkbox"/> B2CT-12D-18-7 | <input type="checkbox"/> B2CT-16D-18-7 |
| <input type="checkbox"/> B3CT-18-7 | <input type="checkbox"/> B3CT-12D-18-7 | <input type="checkbox"/> B3CT-16D-18-7 |

### Design and Construction Features

- New bullnose front edge.
- Units are modular, allowing for custom configurations of underbar equipment using standard components.
- 22 gauge type 304 stainless steel body (front and ends).
- Ice bins are 8", 12", or 16" deep (203, 305, or 406mm) .
- Fabricated ice bin available with ice capacity of 63 lbs. (8"-deep bins), 94 lbs. (12"-deep bins), or 125 lbs. (16"-deep bins).
- Bottom and back panels are galvanized steel construction.
- Brushed stainless steel finish.
- Six- or eight-bottle capacity.
- 1½" (38mm) drain.
- Post-Mix Cold plates: aluminum casting with seven stainless steel beverage grade tubing circuits. Cold plates are mounted flush with interior bottom of bowl for easy cleaning and maximum efficiency. Drain is ½" (13mm) NPT. ¼" (6mm) O.D. tubing beverage connection provided.
- Adjustable plastic feet.

### Certifications / Approvals



EG40.02 Rev. 12/10

**Spec sheets available for viewing, printing or downloading from our online literature library at [www.eaglegrp.com](http://www.eaglegrp.com)**

Eagle Foodservice Equipment, Eagle MHC, SpecFAB®, and Retail Display are divisions of Eagle Group. ©2010 by the Eagle Group



Profit from the Eagle Advantage®

Item No.: \_\_\_\_\_  
 Project No.: \_\_\_\_\_  
 S.I.S. No.: \_\_\_\_\_

# 1800 Series Cocktail Units

## Models without Post-Mix Cold Plate

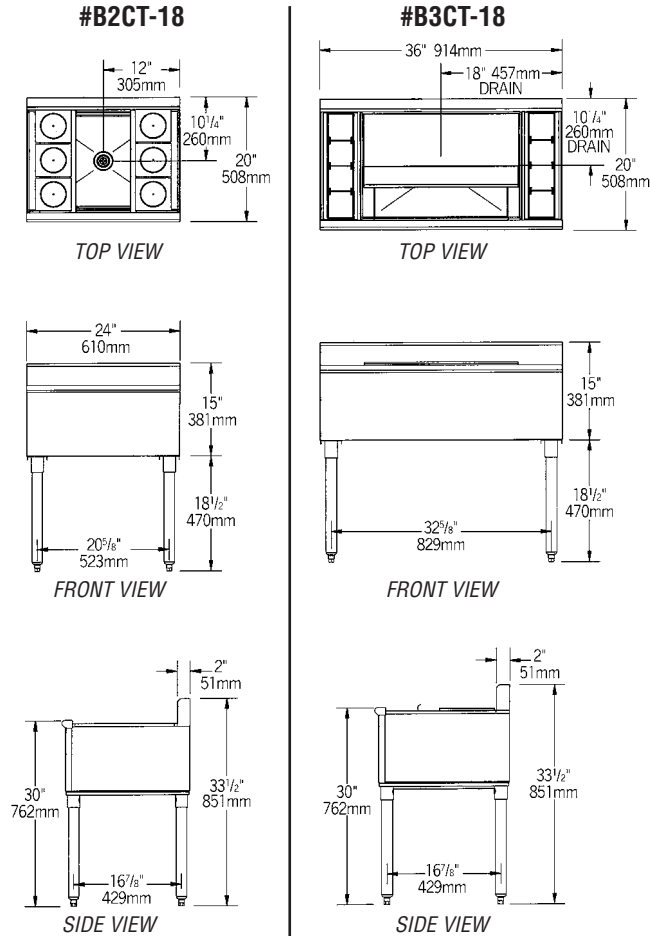

## Models with Post-Mix Cold Plate\*

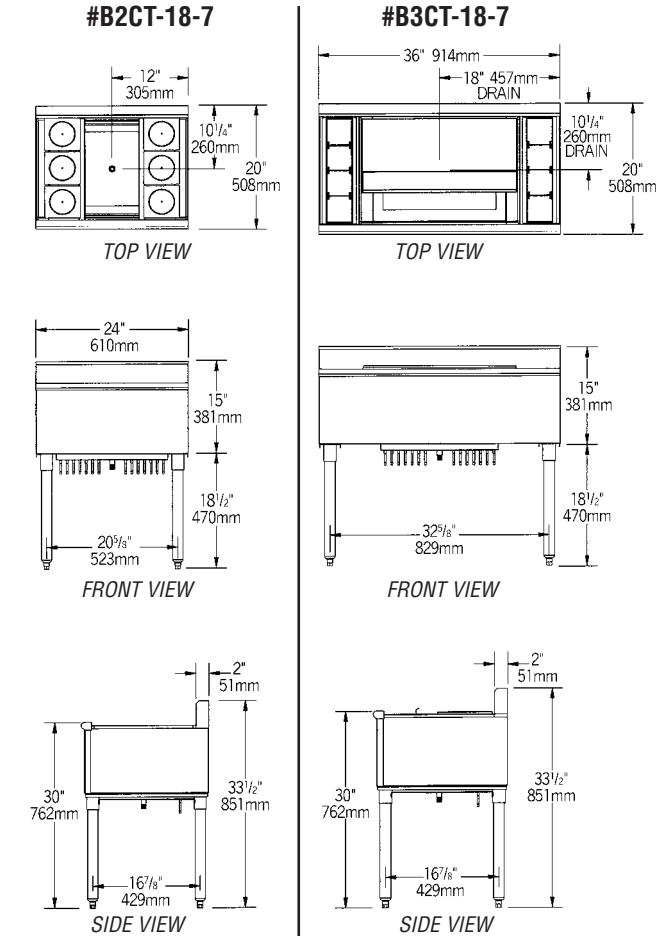

model #	width x length in. mm	shipping weight* lbs. kg	ice bin depth in. mm	ice capacity lbs. kg
B2CT-18	20" x 24" 495 x 610	52 23.6	8" 203	63 28.6
B2CT-12D-18	20" x 24" 495 x 610	55 24.9	12" 305	94 42.6
B2CT-16D-18	20" x 24" 495 x 610	58 26.3	16" 406	125 56.7
B3CT-18*	20" x 36" 495 x 914	72 32.7	8" 203	63 28.6
B3CT-12D-18**	20" x 36" 495 x 914	75 34.0	12" 305	94 42.6
B3CT-16D-18**	20" x 36" 495 x 914	78 35.4	16" 406	125 56.7

model #	width x length in. mm	shipping weight* lbs. kg	ice bin depth in. mm	ice capacity lbs. kg
B2CT-18-7	20" x 24" 495 x 610	146 66.2	8" 203	63 28.6
B2CT-12D-18-7	20" x 24" 495 x 610	149 67.6	12" 305	94 42.6
B2CT-16D-18-7	20" x 24" 495 x 610	151 68.5	16" 406	125 56.7
B3CT-18-7**	20" x 36" 495 x 914	219 99.2	8" 203	63 28.6
B3CT-12D-18-7**	20" x 36" 495 x 914	221 100.2	12" 305	94 42.6
B3CT-16D-18-7**	20" x 36" 495 x 914	224 101.6	16" 406	125 56.7

\* Units with cold plate shipped in wooden crates.  
 \*\* "B3" units include stainless steel sliding cover.

**EAGLE GROUP**  
 100 Industrial Boulevard, Clayton, DE 19938-8903 USA  
 Phone: 302-653-3000 • Fax: 302-653-2065  
 www.eaglegrp.com

Foodservice Division: Phone 800-441-8440  
 MHC/Retail Display Divisions: Phone 800-637-5100

Spec sheets available for viewing, printing or downloading from our online literature library at [www.eaglegrp.com](http://www.eaglegrp.com)

Although every attempt has been made to ensure the accuracy of the information provided, we cannot be held responsible for typographical or printing errors. Information and specifications are subject to change without notice. Please confirm at time of order.

Printed in U.S.A.  
 ©2010 by Eagle Group  
 Rev. 12/10