



TempStar™

Project _____
 Item _____
 Quantity _____
 CSI Section 11400 _____
 Approval _____
 Date _____

Models

- TempStar™



Standard Features

- Sani-Sure™ feature assures proper rinse water temperature
- Multi-cycle timer (Extra Heavy, Heavy, Medium, Normal)
- Specially designed stainless steel nozzels provide superior cleaning action
- 17-1/4" (438 mm) door opening accepts 18" (457 mm) trays
- Interchangeable wash/rinse arms screw out for simple cleanup
- Auto-fill / auto-start
- Safety door switch
- Delime/manual wash switch
- Low watt density electric wash tank heater
- Hi-limit thermostat and low water protection
- Top mounted controls for ease of installation
- Adjustable bullet feet
- Uses standard 20" X 20" (508 mm X 508 mm) racks
- Front dress panel
- Detergent/rinse additive signal connection fuse box
- Self-draining stainless steel pump
- Built-in 40°F (4°C) booster heater is standard; 70°F (21°C) booster is available but must be specified at time of order
- Large scrap tray

Mandatory Specs

- Specify voltage
- Specify booster size
- Specify electric or steam heat

Optional Features

- Optional 70°F (21°C) rise booster heater is available with no additional cost (must be specified).
- Drain quench system
- Scaltrol
- Water hammer arrestor
- Flanged feet

Accessories

- 36" (914 mm) compartment rack 4-1/6" (4 mm) tall
- 36" (914 mm) compartment rack 5-5/8" (16 mm) tall
- 36" (914 mm) compartment rack 7" (178 mm) tall
- Combination rack
- Peg rack

Specifications

Uses 1 gallon (4 liters) of water per rack

Total automatic (normal) cycle - 58 seconds

57 racks per hour (normal) cycle

3/4 HP Wash Pump Motor

Single point connections for all utilities

Built-in water pressure regulator and gauge

Field convertible from straight through to corner operations

Heavy duty stainless steel construction



Highway 25E
 P. O. Box 1060
 Barbourville, KY 40906

Tel: 606-523-9795
 Tel: 1-888-800-5672
 Fax: 606-523-9196
 E-mail: info@jacksonmsc.com

www.jacksonmsc.com
 07610-002-66-59 (09/07)



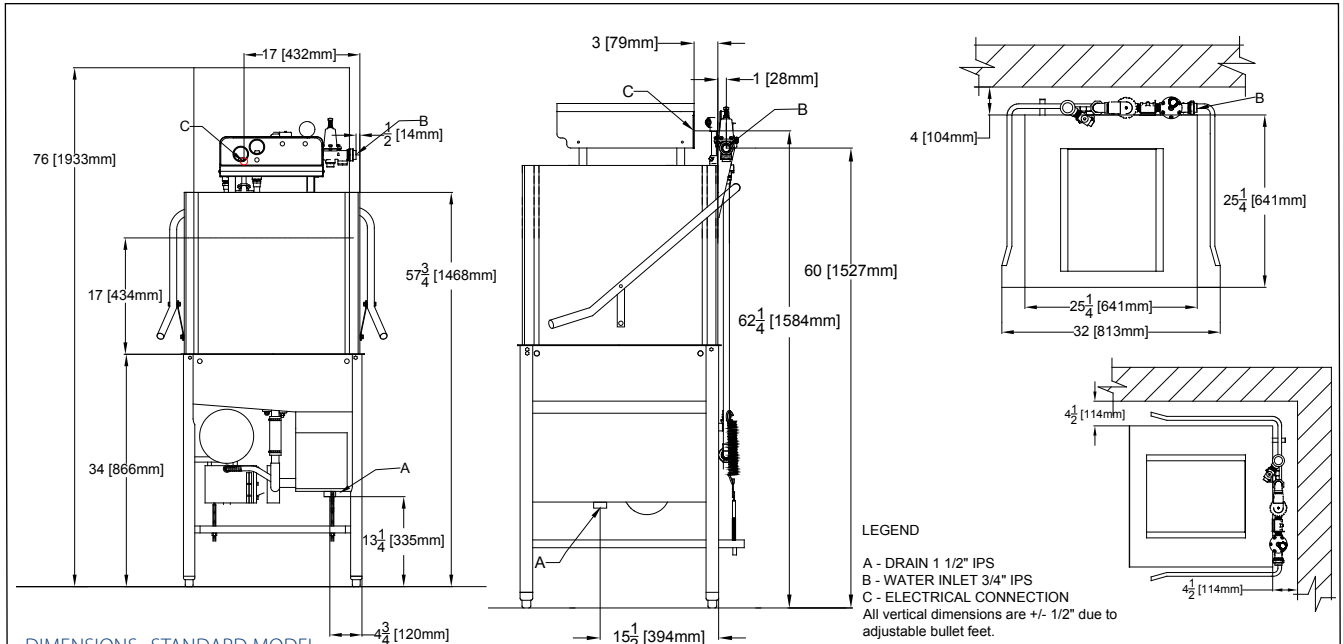

DIMENSIONS--STANDARD MODEL

MODEL NO.	SIZE			DRAIN HEIGHT	SHIPPING INFO			DIMENSIONS		
	HEIGHT	WIDTH	DEPTH		WEIGHT	CLASS	CUBE	HEIGHT	WIDTH	DEPTH
TempStar™	64-3/8" (1635 mm)	25-1/4" (641 mm)	25-1/4" (641 mm)	13-1/4" (335 mm)	350 lbs (159 kg)	92.5	37-1/2 cu. ft.	72" (1829 mm)	30" (762 mm)	30" (762 mm)

DIMENSION REQUIREMENTS

Wall Clearance (Minimum)	4" / (102 mm)
Standard Table Height	34" / (864 mm)
inside Clearance	17-1/4" / (438 mm)

STEAM REQUIREMENTS

Steam Flow Pressure (PSIG)	15-20
Consumption @ 15 PSIG (lbs./hr.)	45

OPERATING CAPACITY

Racks per Hour	Normal	Medium	Heavy	Extra Heavy
	57	29	19	11
OPERATING CYCLE (sec)	Wash	Rinse	Dwell	Total Cycle
Normal	45	11	2	58
Medium	103	11	2	116
Heavy	163	11	2	176
Extra Heavy	283	11	2	294

WATER REQUIREMENTS

Inlet Temperature	
40°F / (4°C) Rise	140°F / (82°C)
70°F / (21°C) Rise	110°F / (60°C)
Gallons per Hour	57 / (216 Ltr.)
Gallons per Rack	1.0 / (4 ltr)
Waterline Size IPS (Minimum-inches)	3/4
Drainline Size IPS (Minimum-Inches)	1-1/2
Flow Pressure (PSI)	15-25
Wash Tank Capacity	8 Gal. / (30 ltr)
Booster Tank Capacity	3 Gal. / (11 ltr)

OPERATING TEMPERATURES

Wash (Minimum)	150°F / (66°C)
Rinse (Minimum)	180°F / (82°C)

WASH PUMP MOTOR

Wash Pump Motor Horsepower	3/4 HP		
	Volts	KW	
Electric Wash Tank Heater	208V	4.1	
	230V	5.0	
	460V	5.0	
Electric Rinse Tank Heater	40°F (4°C) Rise	208V	9.0
		230V	11.0
		460V	11.0
	70°F (21°C) Rise	208V	10.5
		230V	12.9
		460V	12.9

APPROXIMATE LOAD AMPS

	40°F (4°C) Rise	70°F (21°C) Rise
Power Supply	AMPS	AMPS
208V/60HZ/1PH	68.7	75.8
208V/60HZ/3PH	42.1	46.3
230V/60HZ/1PH	75.4	83.6
230V/60HZ/3PH	45.5	50.7
460V/60HZ/3PH	21.7	24.1

How To Specify - TempStar™

Highway 25E
 P. O. Box 1060
 Barbourville, KY 40906

Tel: 606-523-9795
 Tel: 1-888-800-5672
 Fax: 606-523-9196
 E-mail: info@jacksonmsc.com

www.jacksonmsc.com
 07610-002-66-59 (09/07)