



IMPERIAL ELECTRIC BOOSTER WATER HEATERS

Models S-6, -7, -9, -12, -13, -15, -17, -18, -24, -27, -30, -36, -39, -40, -45, -54, -57

The Hatco Imperial Electric Booster Water Heater combines quality construction and rugged dependability to provide up to 573 GPH (2169 LPH) of sanitizing rinse water. Dishes and flatware *air-dry* instantly to save time, space, and money. Storage capacity is 16 gallons (60 liters).

FLEXIBILITY

Models available from 6kW to 57kW in 208, 240, and 480 volts with other voltages available. The Imperial Electric Booster Heater thermostats can be lowered to a 140° F (60° C) setting for low-temp dishmachines.

Service area is accessible from the front to permit easy installation, even next to other equipment.

QUALITY

The following features assure the finest performance for years to come:

- All models include a Castone® lined tank with a 10-year limited warranty.
- Features include a temperature/pressure relief valve, a pressure reducing valve, two temperature/pressure gauges, a high-temperature limit control, pilot indicator light, on-off switch, and a low-water cut-off to prevent element burnout due to low water condition.
- Each booster has a built-in heat trap and fiberglass insulation to minimize heat loss.
- Hatco electric booster heaters are factory pre-plumbed and pre-wired with calibrated immersion thermostats and high-temperature limit switch.
- A stainless steel front panel and powder-coated silver-gray hammertone body is standard on all Imperial models.



Model S-54

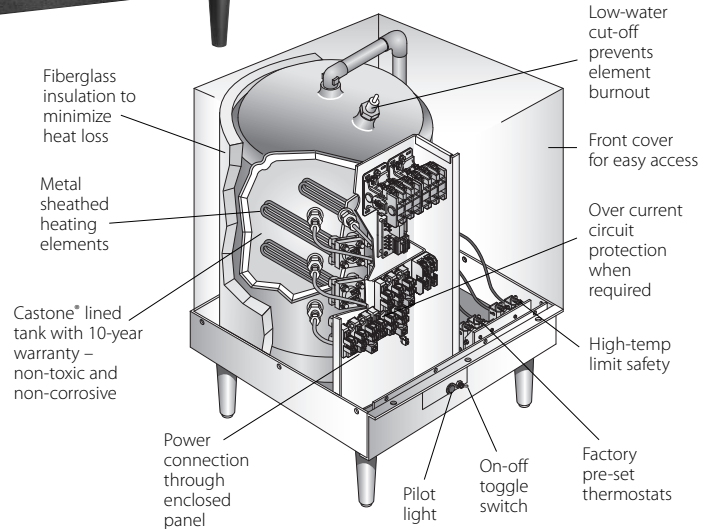

Water Temperature Recovery Table

Imperial Model	40° F (22° C) Rise	70° F (39° C) Rise
S-6	60 gph (227 lph)	34 gph (129 lph)
S-7	70 gph (265 lph)	40 gph (151 lph)
S-9	90 gph (341 lph)	52 gph (197 lph)
S-12	120 gph (454 lph)	69 gph (261 lph)
S-13	135 gph (511 lph)	77 gph (292 lph)
S-15	151 gph (572 lph)	86 gph (326 lph)
S-17	173 gph (655 lph)	99 gph (375 lph)
S-18	181 gph (685 lph)	103 gph (390 lph)
S-24	241 gph (912 lph)	138 gph (522 lph)
S-27	271 gph (1026 lph)	155 gph (587 lph)
S-30	301 gph (1139 lph)	172 gph (651 lph)
S-36	361 gph (1367 lph)	206 gph (780 lph)
S-39	391 gph (1480 lph)	224 gph (848 lph)
S-40	407 gph (1541 lph)	232 gph (878 lph)
S-45	452 gph (1711 lph)	258 gph (977 lph)
S-54	542 gph (2052 lph)	310 gph (1174 lph)
S-57	573 gph (2169 lph)	326 gph (1234 lph)

WATER QUALITY REQUIREMENTS

Incoming water in excess of 3.0 grains of hardness per gallon (GPG) (.75 grains of hardness per liter) must be treated and softened before being supplied to booster heater(s). Water containing over 3.0 GPG (.75 GPL) will decrease the efficiency and reduce the operating life of the unit.

Note: Product failure caused by liming or sediment buildup is not covered under warranty.



HATCO CORPORATION P.O. Box 340500 Milwaukee, WI 53234-0500 U.S.A.
 (800) 558-0607 • (414) 671-6350 • Fax (800) 543-7521 • Int'l. Fax (414) 671-3976
www.hatcocorp.com • E-mail: equipsales@hatcocorp.com



IMPERIAL ELECTRIC BOOSTER WATER HEATERS

Models S-6, -7, -9, -12, -13, -15, -17, -18, -24, -27, -30, -36, -39, -40, -45, -54, -57

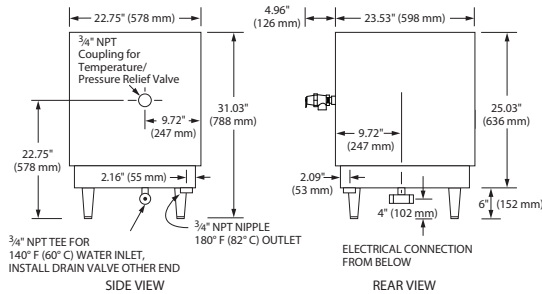

DIMENSIONS

23.53"W x 22.75"D x 31.03"H with 6" (152 mm) legs (598 x 578 x 788 mm).

† Add 4.96" (126 mm) for pressure relief valve.

Working Pressure of Tanks: 150 psi (1034 kPa) – tested at 300 psi (2069 kPa).

VOLTAGE

208, 240, and 480 volts available. Export voltages available.

SPECIFICATIONS

Model	kW	1-Phase			3-Phase		Shipping Weight
		Volts	Amps	Breaker/Fuse Size	Amps	Breaker/Fuse Size	
S-6*	6	208	29	40	25*	40	200 lbs. (91 kg)
		240	25	40	22*	30	
		480	–	–	11*	15	
S-7*	7	208	34	50	29*	40	200 lbs. (91 kg)
		240	29	40	25*	40	
		480	–	–	13*	20	
S-9*	9	208	43	60	38*	50	200 lbs. (91 kg)
		240	38	50	33*	50	
		480	–	–	16*	20	
S-12	12	208	58	90	33	50	200 lbs. (91 kg)
		240	50	70	29	40	
		480	–	–	14.5	20	
S-13	13.5	208	65	90	38	50	200 lbs. (91 kg)
		240	56.3	90	33	50	
		480	–	–	16.3	30	
S-15	15	208	72	90	41.7	60	200 lbs. (91 kg)
		240	62.5	90	36.1	50	
		480	–	–	18.1	30	
S-17†	17.2	208	–	–	47.9	60	200 lbs. (91 kg)
S-18§	18	208	86.5	125	–	–	200 lbs. (91 kg)
		240	75	100	43.4	60	
		480	–	–	21.7	30	
S-24	24	208	115.4	150	67.7	90	214 lbs. (97 kg)
		240	100	125	57.8	90	
		480	–	–	29.9	40	
S-27	27	208	129.8	175	75	100	214 lbs. (97 kg)
		240	112.5	150	65	90	
		480	–	–	32.5	50	

Model	kW	1-Phase			3-Phase		Shipping Weight
		Volts	Amps	Breaker/Fuse Size	Amps	Breaker/Fuse Size	
S-30	30	208	144	200	83.3	125	214 lbs. (97 kg)
		240	125	175	72.3	100	
		480	–	–	36	50	
S-36	36	208	173	225	100	125	214 lbs. (97 kg)
		240	150	200	86.7	125	
		480	–	–	43.3	60	
S-39	39	208	187.5	250	108	150	214 lbs. (97 kg)
		240	163.5	225	94	125	
		480	–	–	47	60	
S-40	40.5	208	–	–	112	150	224 lbs. (102 kg)
		240	–	–	97	125	
		480	–	–	49	60	
S-45*	45	208	–	–	125	175	224 lbs. (102 kg)
		240	188	250	108	150	
		480	–	–	54	70	
S-54*	54	208	–	–	150	200	224 lbs. (102 kg)
		240	–	–	130	175	
		480	–	–	65	90	
S-57*	57	208	–	–	158.4	200	224 lbs. (102 kg)
		240	–	–	137.3	175	
		480	–	–	68.6	90	

* Only 6, 7, & 9kW Models, 208 and 240 volts only, can be field converted to single phase (units are shipped 3-phase open delta). Larger branch circuit required than for balanced 3-phase of equal kW. (Balanced 3-phase available, consult factory.)

† 17.2kW models available in 208V 3-phase only.

§ 18kW models not available in 208V 3-phase.

• Not available in 208V single phase.

– Not available in 208V or 240V single phase.

OPTIONS (NOT FOR RETROFIT)

- All Stainless Steel Body and Base
- Security Package

ACCESSORIES

- Blended Phosphate Water Treatment System

- Shock Absorber – To Reduce Water Hammer
- Back Pressure Relief Valve
- Brass Pressure Reducing Valve with Bypass
- Floor Mounting Hardware
- Adjustable Stainless Steel Legs 6" to 7" (152 to 178 mm)

PRODUCT SPECS

Electric Booster Water Heater

The Electric Booster Water Heater to supply the final 180°F (82°C) rinse for the dishwasher shall be an Imperial Model ...as manufactured for commercial use by the Hatco Corporation, Milwaukee, WI 53234 U.S.A.

With 24/7 service (U.S. and Canada only), the booster shall have the capacity to heat ... gph (lph) from ...°F to 180° F (... °C to 82° C) and it shall be rated at ... kW, ... volts, ... phase. The tank shall be designed for a working pressure of 150 psi (1034 kPa) and include a Hatco Castone® lining.

The heater shall be complete with all internal plumbing, including 3/4" NPT pipe and fittings for inlet and outlet. All controls shall be built-in, including contactors and prewired in accordance with UL #1453 and

422.11 NEL 2002. Proper surface mounting circuit breaker or fused disconnect switch shall be provided by electrical contractor.

Electric heating elements shall be metal sheathed, controlled by ambient compensating thermostats. The booster shall be protected with high temperature limit switch (ECO) and low-water cut-off.

The heater shall consist of stainless steel front and silver-gray hammertone body with standard 6" (152 mm) legs (or stainless steel body, base, and stainless steel adjustable legs).

The heater shall include a temperature/pressure relief valve, high-temperature pressure reducing valve with bypass, and two indicating temperature/pressure gauges.

HATCO CORPORATION P.O. Box 340500 Milwaukee, WI 53234-0500 U.S.A. • (800) 558-0607 • (414) 671-6350
Fax (800) 543-7521 • Int'l. Fax (414) 671-3976 • www.hatcocorp.com • E-mail: equipsales@hatcocorp.com