



Direct Steam Kettle model FT

Description

Kettle shall be Groen Model FT (specify 20, 40, 60, 80, 100, 125 or 150-gallon) stainless steel, 2/3 jacketed unit operating from direct steam.

Construction

Kettle shall be of type 316 stainless steel, solid one-piece welded construction. Unit shall be provided with a heavy, durable bar rim with a continuous seal weld on the underside to ensure maximum durability and sanitation. Unit provided with faucet bracket as standard.

Finish

Interior of kettle shall be polished to a 180 emery grit finish. Exterior of kettle shall be finished to a bright high buff finish, ensuring maximum ease in cleaning and maintaining brilliant appearance.

ASME Code

Unit shall be ASME shop inspected, stamped and registered with the National Board for operation up to a maximum working pressure of 25 PSI.

Sanitation

Unit shall be designed and constructed to meet NSF and known health department and sanitation codes, and be NSF listed.

Drawoff

Unit shall have a 2" sanitary tangent drawoff which is a 316 stainless steel compression disc drain valve, for easy disassembly without tools. Larger 3" drawoffs available. The drain outlet shall be equipped with a removable 1/4" perforated stainless steel strainer.

Cover

Cover shall be one piece stainless steel dome shaped and hinged. Counterbalanced #51 spring assisted cover for 60, 80, 100, 125 and 150 gallon units.

Steam Pressure

Kettle shall operate dependably at any steam pressure between 5 and 25 PSI. Higher working pressure available.

Mounting

Unit shall be mounted on an all stainless steel, tubular legs, continuously welded to kettle, with stainless steel adjustable floor flanges. Floor flanges and mounting bolts shall be provided with sanitary covers.

Installation

Remote steam source required. Steam trap assembly is required and not provided unless ordered as an option. See dimension L on other side for steam inlet size and number.

Model FT shown



Options/Accessories

- Basket inserts (TRI-BC)
- Water fill faucets
- Higher working pressure
- 3" tangent drawoff
- Cold water cooling
- Steam trap assemblies
- Kettle brush kit
- 1/8" perforated disc strainer
- 1/4" perforated disc strainer
- Solid disc strainer
- Steam regulators
- Contour measuring strip
- Gallon etch marks

Origin of Manufacture

Kettle shall be designed and manufactured in the United States.

**Stainless Steel
2/3 Steam Jacketed Kettle**

**Floor Mounted
Stationary
Direct Steam
20 to 150-Gallon
Capacities**

Short Form

Groen Model FT (Specify gallons) stainless steel, 2/3 jacketed, direct steam stationary kettle. Solid one piece welded construction, with heavy duty reinforced bar rim. 2" sanitary tangent drawoff standard. Standard units fitted with faucet bracket and one piece dome cover. NSF listed, ASME code constructed for 25 PSI. Unit to be mounted on stainless steel tubular legs, continuously welded to kettle, with stainless steel adjustable floor flanges and sanitary covers. Made in USA.



Applications

- Wet roasting meats
- Soups
- Stews
- Stocks
- Poultry
- Sauces
- Pie Fillings
- Vegetables
- Pasta
- Rice
- Gravies

TABLE OF DIMENSIONS

CAP. GAL.	20		40		60		80		100	
	INCH	MM	INCH	MM	INCH	MM	INCH	MM	INCH	MM
A	20	508	26	660	30	762	32	813	36	914
B	27 1/2	699	33	838	37	940	38	965	40	1016
C	24	610	30	762	34	864	36	914	40	1016
D	59	1499	65	1651	67	1702	73	1854	77	1956
E	36	914	36	914	39	991	43	1092	44	1118
F	12	305	14 1/2	368	15	381	15	381	15	381
G	15 3/4	400	11 3/4	299	11 3/4	299	11 3/4	299	11 3/4	299
H	18	457	25	635	-	-	-	-	-	-
J	8	203	10 1/4	260	11 1/2	292	12 1/4	311	13 1/2	343
K	18 7/8	479	15 3/4	400	16 1/4	413	16 1/2	419	17 1/2	445
L	18 1/2	470	22	559	25	635	29	734	30	762
M	1/2	-	1/2	-	1/2	-	3/4	-	3/4	-
N	1/2	-	3/4	-	3/4	-	1	-	1	-
P	9 1/4	235	11 3/4	299	13 1/2	343	14 1/4	362	15 7/8	403
R	14	356	16	406	17	432	17	432	17	432
S	14 3/4	375	10 3/4	273	10 3/4	273	10 3/4	273	10 3/4	273

- NOTES:
1. KETTLE MUST BE SECURELY ANCHORED TO FLOOR. FLOOR FLANGES ARE THREADED AND HEIGHT ADJUSTABLE.
 2. SANITARY (1) PIECE DOME COVER SHOWN - FURNISHED ON 20 & 40 GALLON SIZES.
 3. MODEL # 51 COUNTER BALANCED COVER FURNISHED ON KETTLES 60 GALLONS AND OVER.
 4. POSITION CENTER OF TANGENT DRAWOFF SPOUT 4"-5" OVER FLOOR DRAIN FOR PROPER DRAINAGE.
 5. DIMENSIONS IN BRACKETS () ARE MM.

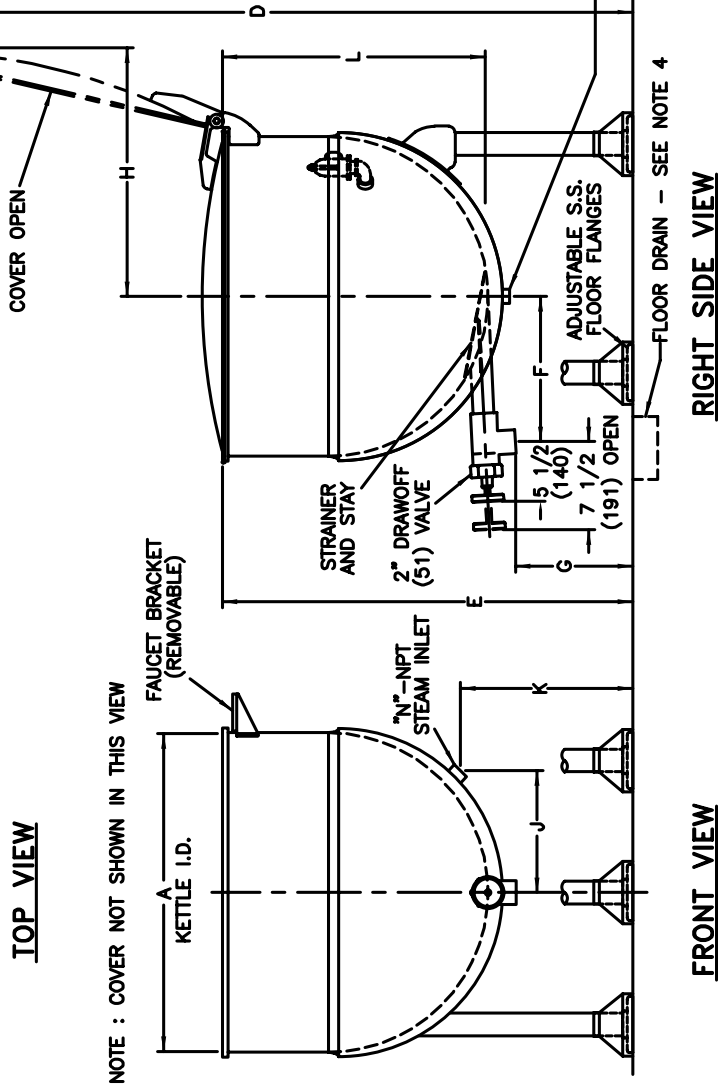
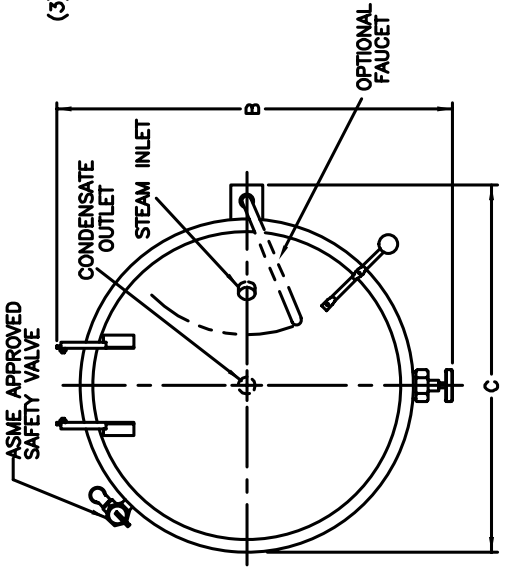
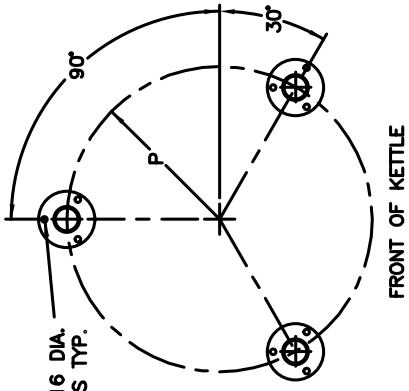
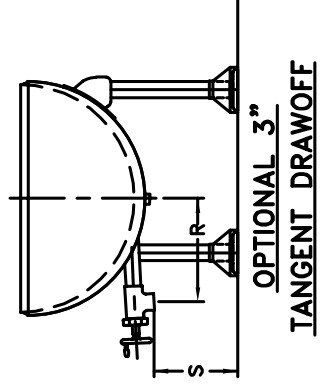

NOTE : COVER NOT SHOWN IN THIS VIEW

