



a **Standex** company

ITEM: \_\_\_\_\_ PROJECT NAME: \_\_\_\_\_ DATE: \_\_\_\_\_

## COUNTER TOP SIGNATURE SERIES REFRIGERATED REAR MOUNT

MODEL CRR3628

CRR4828

## REFRIGERATED BOTTOM MOUNT

MODEL CRB3628

CRB4828



*The Signature Series counter top merchandiser combines attractive curved glass styling and merchandising flexibility. Designed for continuous case line-ups. Cases are available in lengths of 3' and 4'.*

### STANDARD FEATURES

- Curved glass styling.
- Adjustable black wire shelves. Shelves are adjustable up and down and can also be tilted in two positions. Two tiers.
- Tempered thermopane front glass. Acrylic end panels.
- Shielded top light and shelf lights.
- Removable sliding rear doors, shelf lights, shelf supports, and shelves.
- Thermometer.
- Removable, scratch-resistant, rustproof black display deck.
- Condensate evaporator provided for a totally self-contained system.
- Oversized coil and low-velocity fan system maintains high humidity and product freshness.
- Easily accessible light switch and adjustable temperature control.
- Average case temperature of 38° F to 40° F is maintained.
- Black painted metal and stainless construction. Black trim.
- Designed for continuous line-ups.
- 134A Refrigerant.
- Cord and plug (NEMA 5-15P).
- Installation Flexibility
- Set directly on counter with condensing component mounted on rear (CRR Models).
- Recessed 3" in the counter with condensing component mounted underneath (CRB Models).
- UL Safety and UL Sanitation Listed.

# SIGNATURE SERIES REFRIGERATED COUNTER TOP MERCHANDISER

## OPTIONAL ACCESSORIES:

- |  |   |
|--|---|
| <input type="checkbox"/> Glass Shelves         | <input type="checkbox"/> Remote Refrigeration |
| <input type="checkbox"/> Reflective Ends       | <input type="checkbox"/> Chocolate Package    |
| <input type="checkbox"/> Reflective Rear Doors | <input type="checkbox"/> LED Lighting         |

### REAR MOUNT

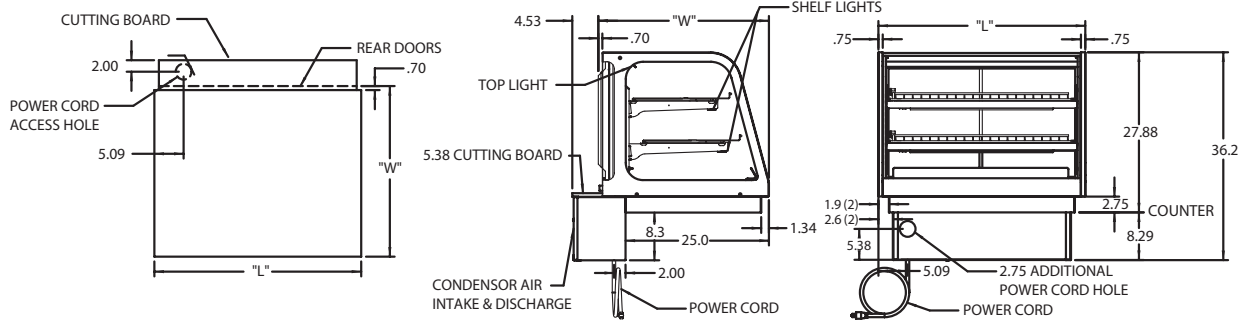

### BOTTOM MOUNT

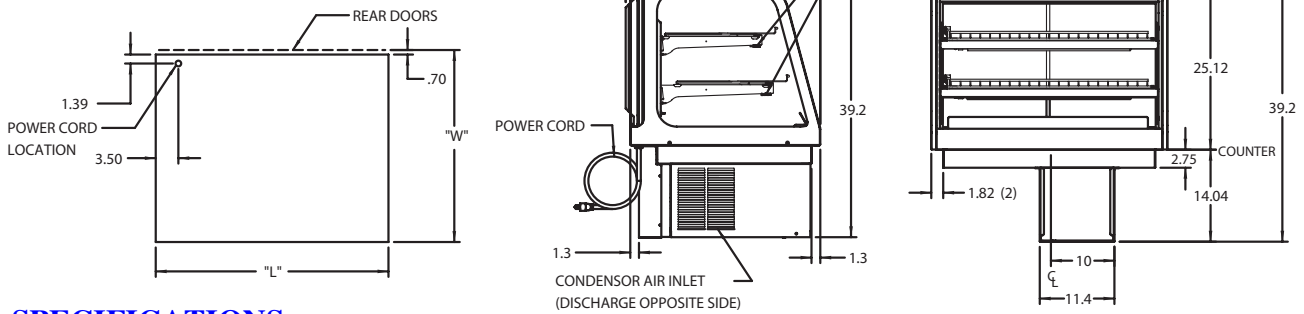

## SPECIFICATIONS:

Model	Dimensions*			Shipping Weight (lbs)	Self-Contained 120/60/1	Remote 120/60/1Rear Mount
	L	W	H			
<b>Rear Mount</b>						
CRR3628	36.0"	29.7"	27.83"	430	8.1 AMPS	1.5 AMPS
CRR4828	48.0"	29.7"	27.83"	500	8.3 AMPS	1.5 AMPS
<b>Bottom Mount</b>						
CRB3628	36.0"	29.7"	25.12"	430	8.1 AMPS	3.6 AMPS
CRB4828	48.0"	29.7"	25.12"	500	8.3 AMPS	3.8 AMPS

\* Height above counter.

- If a GFCI circuit is required, a GFCI Breaker Must be used instead of GFCI receptacle.
- Refrigerated cases are designed to operate in an environment of 75° ambient and 55% relative humidity.
- Due to continuing engineering improvements, specifications are subject to change without notice.



## Look to Federal for Innovative Merchandising



*The Signature of Quality*

**FEDERAL INDUSTRIES**  
A Standex Company

215 FEDERAL AVENUE, BELLEVILLE, WISCONSIN 53508-9201

PHONE: 800-356-4206

EMAIL: [geninfo@federalind.com](mailto:geninfo@federalind.com)

FAX: 608-424-3234

WEBSITE: [www.federalind.com](http://www.federalind.com)

