



WOOD TOP BAKERS TABLES with Coved Risers



TBS-TBG Series
with Open Base



BS-BG Series
with Undersheff



BST-BGT Series
with 3 Tier Drawers

**FOR MAPLETEX TABLES WITH
COVED RISERS, PLEASE
CONSULT FACTORY**

TBS-TBG Series Open Base

Approx. Shipping Weight
is 30 lbs. per lineal foot

BS-BG Series Undersheff

Approx. Shipping Weight
is 35 lbs. per lineal foot

BST-BGT Series 3 Tier Drawer

Approx. Shipping Weight
is 40 lbs. per lineal foot



Item #: _____ Qty #: _____

Model #: _____

Project #: _____

Stainless Steel Base Galvanized Base

Length	30" Wide	36" Wide	30" Wide	36" Wide
48"	TBS-304	TBS-364	TBG-304	TBG-364
60"	TBS-305	TBS-365	TBG-305	TBG-365
72"	TBS-306	TBS-366	TBG-306	TBG-366
84"	TBS-307	TBS-367	TBG-307	TBG-367
96"	TBS-308	TBS-368	TBG-308	TBG-368

Stainless Steel Base Galvanized Base

Length	30" Wide	36" Wide	30" Wide	36" Wide
48"	BS-304	BS-364	BG-304	BG-364
60"	BS-305	BS-365	BG-305	BG-365
72"	BS-306	BS-366	BG-306	BG-366
84"	BS-307	BS-367	BG-307	BG-367
96"	BS-308	BS-368	BG-308	BG-368

Stainless Steel Base Galvanized Base

Length	30" Wide	36" Wide	30" Wide	36" Wide
48"	BST-304	BST-364	BGT-304	BGT-364
60"	BST-305	BST-365	BGT-305	BGT-365
72"	BST-306	BST-366	BGT-306	BGT-366
84"	BST-307	BST-367	BGT-307	BGT-367
96"	BST-308	BST-368	BGT-308	BGT-368

FEATURES & CONSTRUCTION:

Laminated 1-3/4" thick Hard Wood Top with 4" coved corner risers.

Gussets welded to support channels.

BST or BGT Series

Three tier drawer unit features 20" x 20" x 5" Deep Drawn insets mounted on bearing slides.

BS or BG Series

Aluminum die cast "leg-to-shelf" clamp secures shelf to leg eliminating unsightly nuts and bolts. Undersheff is adjustable.

TBS or TBG Series

Front to Back Stretcher is welded to legs. Left to Right Stretcher is bolted to legs and requires assembly.

MATERIAL:

TOP: Laminated 1-3/4" thick hard maple with 4" coved corner risers and reinforced with steel rods.

SHELF: **BS Series:** 18 gauge stainless steel.
BG Series: Heavy gauge galvanized steel.

TIER DRAWER: **BST Series:** 18 gauge stainless steel body, drawer fronts and handles.
BGT Series: Heavy gauge galvanized steel body, drawer fronts and handles.

LEGS: **BS - TBS - BST Series:** 1 5/8" diameter tubular stainless steel gussets and 1" adjustable stainless steel bullet feet.
BG - TBG - BGT Series: 1 5/8" diameter heavy gauge tubular galvanized steel with galvanized steel gussets and 1" adjustable plastic bullet feet.

Spice Bins and Shelf are Available



Customer Service Available To Assist You **1-800-645-3166** 8:30 am - 8:00 pm E.S.T.

Email Orders To: customer@advancetabco.com. For Smart Fabrication™ Quotes, Email To: smartfab@advancetabco.com or Fax To: 631-586-2933

NEW YORK
Fax: (631) 242-6900

GEORGIA
Fax: (770) 775-5625

TEXAS
Fax: (972) 932-4795

NEVADA
Fax: (775) 972-1578

DETAILS and SPECIFICATIONS

TOL ± .500"

Units 8 ft. & larger are furnished with six (6) legs.

ALL DIMENSIONS ARE TYPICAL

TBS-TBG Series Open Base

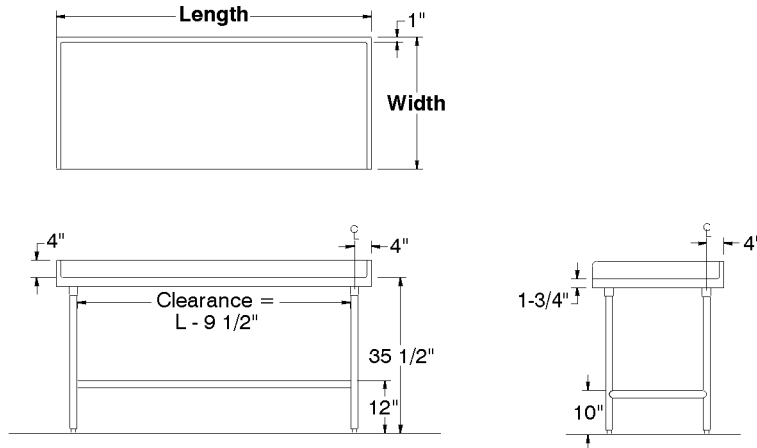

BS-BG Series Undershelf

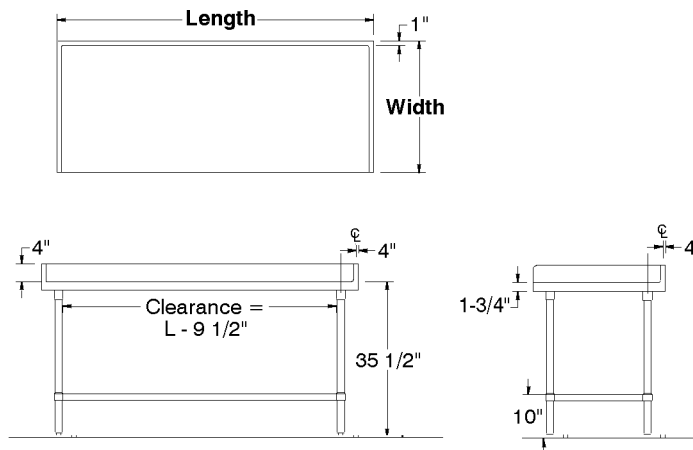

BST-BGT Series 3 Tier Drawer

